



# Operating & Safety Instructions

---

# Operating & Safety Instructions

---

Please read this instruction booklet carefully before operating the product and keep in a safe place for future reference.

It is the responsibility of the purchaser to ensure that operators are properly trained in the safe use of this equipment and have access to **Tangye Operating and Safety Instructions**.

No modification and/or additions may be made to this equipment without the written permission of the manufacturer.

It is expected that the product is used by competent technical personnel who have been properly trained to use hydraulic lifting equipment

## **Hydramite & Hydralite**

### **Description**

This equipment is provided for the purpose of lifting or lowering loads, or exerting a force, under the control of a trained operator.

The equipment is supplied completely assembled and ready for use. No service adjustments are necessary or possible during operation.

An internal safety relief valve (factory set) is fitted which limits the load that may be lifted to the equipment rated load + 10% maximum.

### **Before Each Use**

- Ensure that the jack is in good condition.
- Check the external surfaces for absence of mechanical damage and/or oil leaks. If either is present do not use the equipment and have it serviced.
- Ensure that the external surfaces are dirt free.
- Check the oil level.

### **Operating Instructions**

Place the jack on a firm level foundation fully supporting the jack base, and if necessary place suitable material between the load point and jack ram to avoid damaging the structure to be lifted.

Use the jack by operating the lever in a steady controlled movement at a maximum of 30 strokes per minute.

Remove the operating lever when not in use.

The ram should only be extended hydraulically; it should never be pulled out by hand or used to carry the jack.

**Do Not** position the jack by using the operating lever in the release valve. If the jack is to be placed some distance under the load, use the operating lever in the operating lever/quadrant socket to position the jack.

**Do Not** drop loads onto the jack. If the jack is inadvertently subjected to a shock load, remove from service and have it checked by a competent examiner or service agent.

**Do Not** overload the jack especially when lowering loads.

**Do Not** under any circumstances go under a load when hydraulic jacks solely support it.

If using more than one jack, all the jacks must be able to individually raise the load e.g. two PS620 jacks cannot be used to lift a 30T load as it is impossible to pump both jacks at exactly the same rate, or lower the jacks at exactly the same rate, one of the jacks will end up with an excess load and is liable to fail. In such case two PS630 jacks should be used to raise a load of 30T.

### **Operating Environments**

The jack is intended for use in industrial environments, inside or outside, between temperatures of -20 to +50°C. Outside these limits, or in explosive atmospheres/areas of nuclear radiation, consult the manufacturer before use.

### **Noise and Vibration**

By its design, the jack operates slowly under manual effort. There is no noticeable noise or vibration.

# HYDRAMITE

---

**Fig. 1**

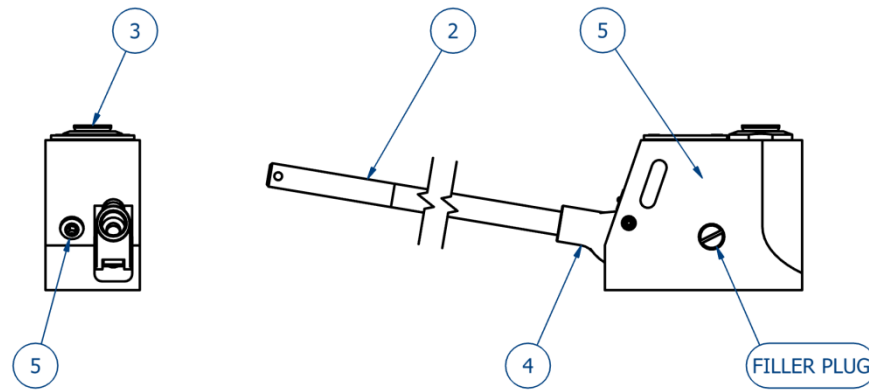

**Function** (read in conjunction with Fig. 1)

The permissible working load and the travel of the hydraulic jack are marked on the equipment.

The jack (1) has an in-built hydraulic pump, which is worked by means of an operating lever (2), under the control of the operator. The jack ram (3) is raised on each downward stroke of the lever. For lifting, the lever is placed fully into the operating socket (4).

For lowering, the lever is removed from the socket and placed into the release screw (5). Turning this anti-clockwise will allow the ram to descend. The amount this is rotated will control the speed of descent; only open a very small amount (approx. 5°) at first.

Close the release valve after use, to ready the jack for the next operation.

## **Operating Positions**

The hydraulic system is sealed – the jack may be used in any mounting position.

## **Oil Level Check**

Lay the jack on its side with the filler plug uppermost and remove the filler plug. There should be no airspace under the plug.

If oil needs to be added ensure that the surrounding area is clean and fill to the bottom of the plug threads. Use high quality hydraulic oil such as Shell Tellus ISO 32 or equivalent.

# HYDRALITE

---

**Fig.2**

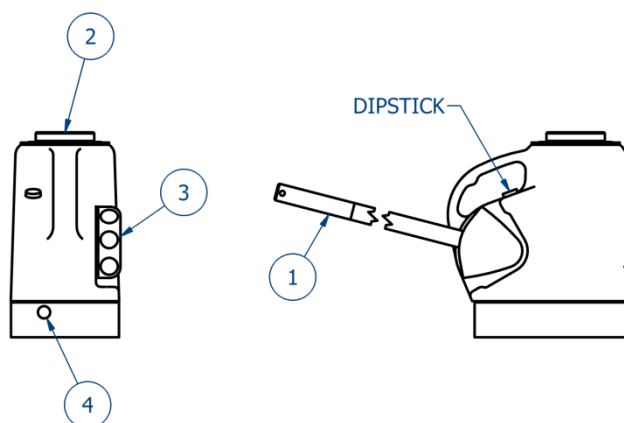

**Function** (read in conjunction with Fig. 2)

The permissible working load and the travel of the hydraulic jack is marked on the equipment, also see table 1.

The jack has an in-built hydraulic pump, which is worked by means of an operating lever (1), under the control of the operator. The jack ram (2) is raised on each downward stroke of the lever. For lifting, the operating lever (1) is placed fully into the operating quadrant (3).

Three positions are provided to enable the operator to choose the best ergonomic position. For lowering, the lever is removed from the quadrant and placed into the release screw (4). Turning this anti-clockwise will allow the ram to descend. The amount this is rotated will control the speed of descent; only open a very small amount (approx. 5°) at first.

Close the release valve, to ready the jack for the next operation.

After use store the jack in an upright position with the ram fully retracted and the operating quadrant in the 'up' position.

**Table 1**

Model	Capacity (tonne)	Stroke (ins)	Claw Capacity (tonne)
PS620	20	6	8
PS1220	20	12	8
PS630	30	6	12
PS1230	30	12	12
PS660	60	6	24
PS1260	60	12	24
P6100	100	6	N/A

Add: **S** for Screwed Ram (for example PS620S)  
**C** for Claw (for example PS620C)

## Jacks with Screwed Rams (Type S)

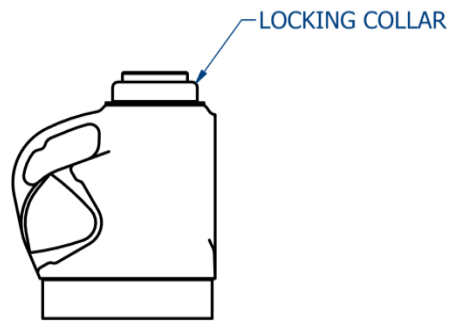

All models can be provided with screwed rams and locking collars. The purpose for this is to mechanically support a load at a required position without relying on the hydraulic circuit.

When the load is at the required position, rotate the locking collar clockwise until it rests hand-tight on the top of the jack body.

To undo – operate the jack so that the hydraulic circuit just takes the load off the locking collar. Rotate the collar anti-clockwise until it reaches the top of the ram.

**Safety Note:** Lifting claws must never be used with screwed ram jacks.

## Jacks with Lifting Claws (Type C)

These claws are supplied as an accessory to provide a low height lifting point. When fitted, lifting must always, and only, be carried out on the toe of the claw.

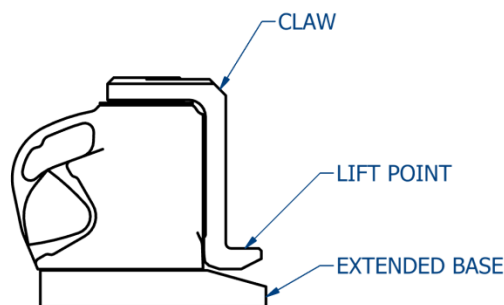

The capacity of the claw is 40% of the capacity of the jack to which it is fitted (See table 1), if the claw is overloaded it could snap and put the operator in danger. Jacks intended for use with claws have extended bases which prevent the jack from toppling over when a load is applied to the claw. Never attempt to use a claw on a jack without an extended base. They must only be used for vertical movements of loads.

The recess in the head of the claw fits around the ram top, and the heel of the claw rests against the front face of the jack. Ensure the claw is seated properly before use and also that the toe is as far under the load as possible.

## 100 Tonne Jacks Only

This jack is fitted additionally with a low pressure pump intended for faster movement of the ram under no load. i.e. to close daylight. The low pressure quadrant is on the left hand side of the jack and operates in the same manner as the high pressure pump.

## Stroke Limit

The jack is fitted with an internal by-pass valve which prevents the ram stroke exceeding the design limit. If the jack is operated in this condition, oil passes back to the reservoir. If operation is continued, some oil may by-pass the ram scraper ring and appear on the top of the jack. Cease operating the jack, wipe off surplus oil and check the oil level of the jack.

## Operating Positions

The jack should only be used in the positions shown below:

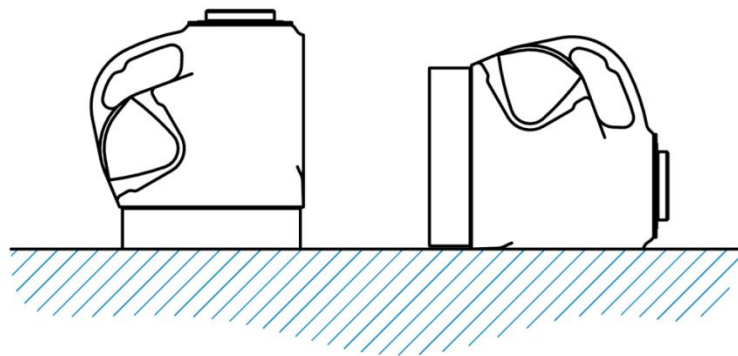

## Oil Level Check

Remove the dipstick (see Fig. 1) and check the oil level. The maximum level is marked on the dipstick; the level should be within 5mm of this mark. The dipstick should be screwed fully into position to determine the level.

If oil needs to be added ensure that the surrounding area is clean. Use high quality hydraulic oil such as Shell Tellus ISO 32 or equivalent.

# HYDRACLAW

---

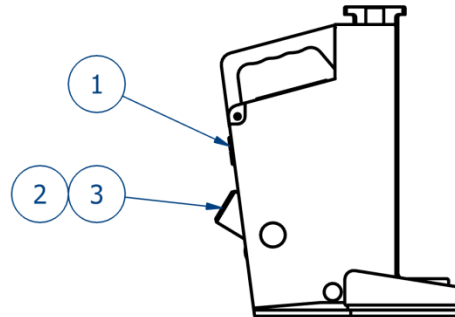

## Description

The jack is constructed from high strength ferrous materials throughout. The forged claw is guided in the body to relieve the ram of bending loads.

## Oil Level Check

The jacks are supplied filled and ready for use. However, before using the jack for the first time, the oil level should be checked. The oil used should be high quality hydraulic oil such as Shell Tellus ISO32 or equivalent.

To check the oil level, stand the jack on its base in an upright position, remove the filler plug and seal (1) and check that the oil is level with the bottom of the filler plug hole.

When refilling from empty, or if air is in the circuit, the following procedure should be observed:

- Ensure that the release valve (2) located inside the operating socket (3) is open. With the jack standing on its base, fill with oil to the bottom of the filler plug hole, replace the filler plug and seal and close the release valve screw.
- Pump the ram/claw to its full extent and turn the jack upside down. Whilst in the inverted position, open the release valve and apply pressure on the jack body to press the ram/claw to its bottom position.
- Repeat this procedure as often as necessary to remove all air from the system. Again stand the jack on its base, remove the filler plug and check the oil is level with the bottom of the filler plughole. If not, top up to this level, replace filler plug and seal.



## **Supporting the Jack**

Before use always ensure the jack is fully supported on a flat, firm surface with due regard to the load to be lifted.

Position the jack so that the load bears centrally on the top of the ram or on the full extent of the claw, ensuring that the load cannot touch any static part of the jack during lifting.

## **Lifting**

The release valve (2) is located inside the operating socket (3) and can be opened or closed by engaging the end of the operating lever. Turning clockwise closes the valve; excessive force is unnecessary and could lead to damage. With the release valve closed and the operating lever in the socket, reciprocate the lever to operate the jack.

The ram will extend on each downward stroke of the lever. When the full extension has been achieved a positive stop is engaged; further pumping will only circulate oil within the jack. This circulation will be apparent to the operator because increased effort is necessary to move the operating lever.

Do not continue pumping after this has been reached.

## **Lowering**

Place the operating lever in the operating socket and ensure that the end of the lever is engaged in the release valve. Carefully turn anti-clockwise. If the jack is under load, turn only a small amount, (approx. 5°); in the first instance which will allow the speed of descent to be controlled by the further extent of the valve opening.

## **Maintenance**

In the normal course of service, no routine maintenance should be required, but attention to the following will assist in obtaining satisfactory service.

The oil level should be periodically checked; the reservoir should not be overfilled. Always use clean oil of the type specified.

Always wipe the claw/ram extension clean before retracting. Lightly grease the claw tenons occasionally.

Inspect and clean ram and jack after every use, if subjected to abnormal or shock loading inspect for damage immediately.

Refer to authorised service centre for testing and service.

## **Safety information**

Always ensure that the full base area of the jack is supported when in use.

Always ensure that loads are applied centrally to the ram or to the full extent of the claw.

Always clean the ram and retract after use.

Always remove the jack operating handle when not in use.

In operation never drop loads onto the jack. Always raise the head/toe to the load.

Never extend the ram by any means other than by pumping the jack.

**Do Not** attempt to exceed the rated load of 5 tonnes on head or toe.

**Do Not** allow any person(s) to work under the load when it is only supported by hydraulic jacks.

**Do Not** use if there is evidence of oil leakage.

## **Allspeeds Ltd**

Royal Works, Atlas Street, Accrington,  
Lancashire, UK BB5 5LW

tel: +44 (0)1254 615100 / fax: +44 (0)1254 615199  
email: [info@allspeeds.co.uk](mailto:info@allspeeds.co.uk) / website: [www.allspeeds.co.uk](http://www.allspeeds.co.uk)