



Original Instructions

for

Hydrapak Pumps

Revision 1 – Issue 3

(MOD 21219)

Allspeeds Ltd.

Royal Works, Atlas Street
Clayton Le Moors, Lancashire, UK.

BB5 5LW
01254 615100

Table of Contents

1	Scope	4
2	Technical Data	5
2.1	Pump Weight.....	5
2.2	Working Fluids.....	5
2.3	Environmental Considerations.....	6
2.4	Noise and Vibration.....	6
3	Hydrapak Selector/Configurator	7
4	Declaration of Conformity	8
5	General Safety Rules	9
5.1	Warnings.....	9
5.2	Important Information	9
5.3	General Safety	9
5.4	Hoses	10
5.5	Maintenance.....	11
5.6	Warning Symbols.....	11
6	Operating Instructions	12
6.1	Installing on Tank.....	12
6.2	Before Use	13
6.3	Close the Release Valve.....	14
6.4	Operating Lever	15
6.5	Connecting the Output.....	16
6.6	Select Low Pressure.....	17
6.7	Pump in Low Pressure Mode.....	17
6.8	Select High Pressure	18
6.9	Pump in High Pressure Mode	18
6.10	Releasing the Pressure	19
6.11	Bleeding Air from the System.....	20
6.12	Greasing the Rocker Shaft	21
6.13	Cleaning the Filter	22

6.14	Pressure Relief Valve.....	23
6.15	Gauges	24
7	After Use.....	25
7.1	Flushing/Draining the Pump.....	25
8	Maintenance.....	27
9	Parts List	29
9.1	Seal Kit Components.....	29
10	Decommissioning	30

1 Scope

This manual covers the operation and maintenance of the Hydrapak range of Tangye hydraulic pumps.

The Hydrapak pump is a lightweight, 2-speed, manually operated pump available in a range of pressures up to 1000 bar (14,500 psi).

As the pump is self-contained, is the ideal solution when no power source is available or when a power source fails.

Please read carefully and work in accordance with this instruction booklet before operating the product and keep in a safe place for future reference.

It is the responsibility of the purchaser to ensure that operators are properly trained in the safe use of this equipment and have access to this document.

No modification and/or additions may be made to this equipment without the written permission of the manufacturer.

It is expected that the product is used by competent technical personnel who have been properly trained to use hydraulic equipment.

2 Technical Data

2.1 Pump Weight

The weight is marked on the nameplate affixed to the side of the pump.

Important: Ensure the correct Manual Handling procedures are carried out when handling the pump. Where a pump has an operating lever, it should be removed from the pump and lifted separately.

2.2 Working Fluids

The standard Hydrapak pump is supplied with nitrile rubber seals. A good quality hydraulic oil (e.g. Shell Tellus 32) is the preferred working media for the pump due to its good lubricating properties.

Alternative acceptable fluids are water, oil/water emulsions, paraffin and glycerine, however using the pump with these fluids may decrease pump life.

When water is used, it should be clean and soft and changed regularly to prevent bacterial growth. The pump body should not be left in contact with water for prolonged periods. After using water in the pump, thoroughly flush clean.

Ethylene Propylene (E.P) seals are available to order.

For compatibility with any other fluid, please contact the manufacturer.

2.3 Environmental Considerations

The pump is intended for use in industrial environments, inside or outside, between temperatures of -20 to $+50^{\circ}\text{C}$. The pump should not be used outside these limits or in explosive atmospheres/areas of nuclear radiation.



2.4 Noise and Vibration

By its design, the pump operates slowly under manual effort. There is no noticeable noise or vibration. The noise level does not exceed 70 dB(A).

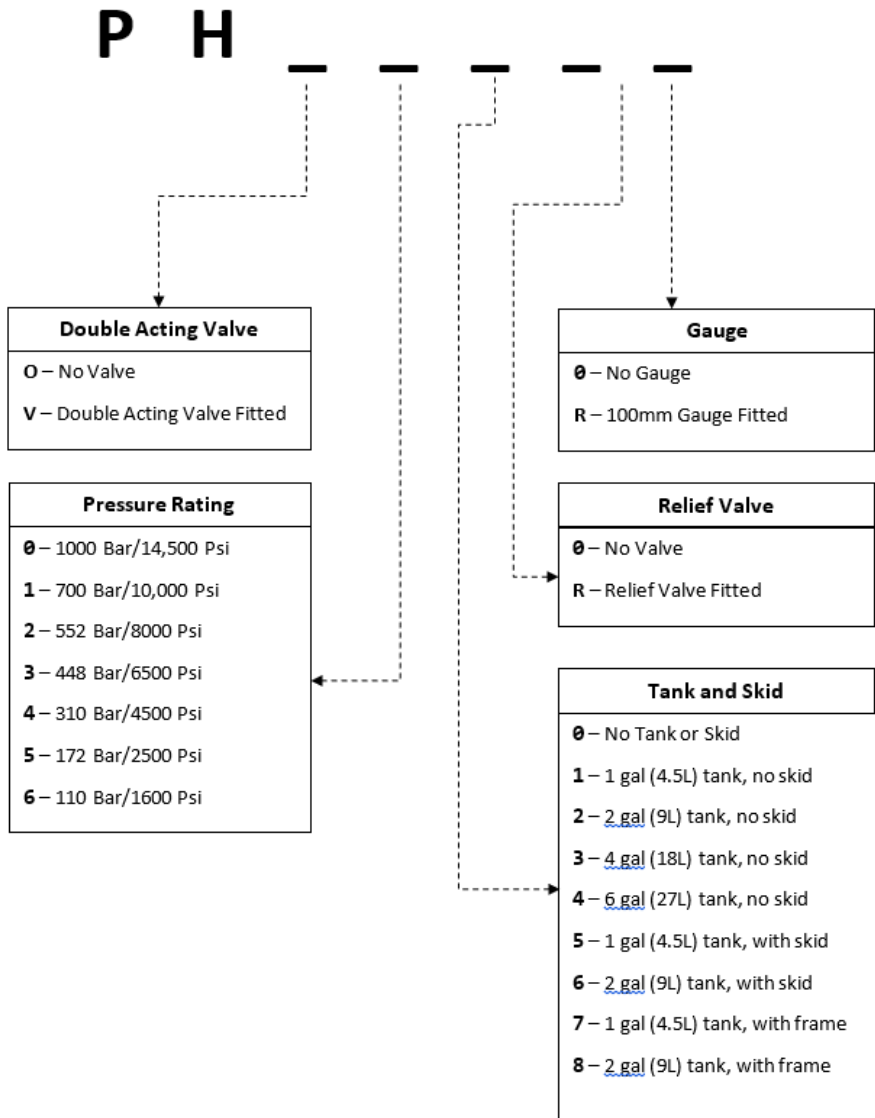
3 Hydrapak Selector/Configurator



4 Declaration of Conformity

		<h1>DECLARATION OF CONFORMITY</h1>	
Company name:		Allspeeds LTD	
Company address:		Royal Works, Atlas Street, Clayton le Moors, Accrington, Lancashire BB5 5LW, UK	
Machinery covered by this declaration:	Description:	Hydraulic Pump	
	Model:	PHO0000, PHO1000, PHO2000, PHO3000, PHO4000, PHO5000, PHO6000 and their variations. All branded equivalents.	
	Type:	Tangye Hydrapak Pumps	
	Serial No.:	All 2022 Serial Numbers	
The machinery conforms to all the requirements of the Machinery Directive 2006/42/EC.			
The machinery also conforms to the following Directives:		n/a	
The following standards have been applied:		n/a	
The technical documentation is compiled in accordance with part A of Annex VII of the Machinery Directive 2006/42/EC			
Person authorised to compile the relevant technical documentation (based in the European Community):	Name:	Authorised Rep Compliance	
	Address:	Ground Floor, 71 Lower Baggot Street, Dublin, D02 P593, Ireland	
The relevant authorised person undertakes to transmit, in response to a reasoned request by the national authorities, relevant information on the machinery. This information will be transmitted by: (email, post)			
Person authorised to make this declaration:	Name:	Keith Elliot	
	Position in company:	Managing Director	
	Signature :		
	Place of Declaration:	Accrington, Lancashire, UK	
	Date of Declaration:	1 st January 2022	

5 General Safety Rules

5.1 Warnings

These warnings are provided to improve safety and should be carefully read before using or maintaining the equipment.

5.2 Important Information

It is vital that these instructions are available to the equipment users. It is also important that they are retained with the equipment if it is sold or transferred to another user.

IMPORTANT - This is an inherently dangerous piece of equipment and is supplied without guarding. It is vital that the installer and end user perform a risk assessment and implement any safety features that they deem necessary and enforce a safe system of work before use.

Allspeeds LTD will not be held responsible for any damage to the equipment or personal injury resulting from unsafe use of the product, lack of maintenance or incorrect operation.

5.3 General Safety

To prevent the risk of injury, the pump should only be used by fully trained and competent operators.

- Make sure that all safety devices are in place and functioning correctly
- Make sure the working area is adequately light and is free of any obstructions

- Only operate the pump in a safe working environment and not during poor weather conditions. (Do not operate during rain/lightning/excessive heat etc.)
- Relieve pressure before disconnecting hydraulic lines and tighten all connections before applying hydraulic pressure.
- In case of accidental skin injection, seek immediate surgical treatment.
- **Failure to follow this warning can result in amputation or serious injury.**

Recommended PPE for operation and maintenance includes safety shoes, safety glasses and gloves.

Any spilt oil may create a slipping or tripping hazard. Care must be taken around the work area.

5.4 Hoses

Ensure that all hoses connected between the Hydrapak pump and any other equipment are rated to a minimum of the rated pump pressure, are fitted correctly and in good condition.

Energised hoses may move during operation and should be fitted with whip-check devices to contain them in case of a burst.



In circumstances where a hose would be subject to undue flexing, sharp bends, or mechanical damage, we recommend the fitting of steel piping.

5.5 Maintenance

We recommend that any servicing of this equipment is carried out by the manufacturer or an authorised service centre.

Details of approved service centres on application to Allspeeds LTD.

5.6 Warning Symbols

	
<p>General Hazard</p> <p>Hydraulic tool with inherently dangerous moving parts.</p>	<p>High Pressure Fluid</p> <p>The pump generates high pressure fluid. Never check for leaks with a hand or other body part. Always drain pressure before working on the pump</p>

6 Operating Instructions

6.1 Installing on Tank

To attach the Hydrapak to a Tangye reservoir, orientate the Hydrapak pump as shown in the image below. Tighten the 4 screws with a maximum torque of 15Nm.

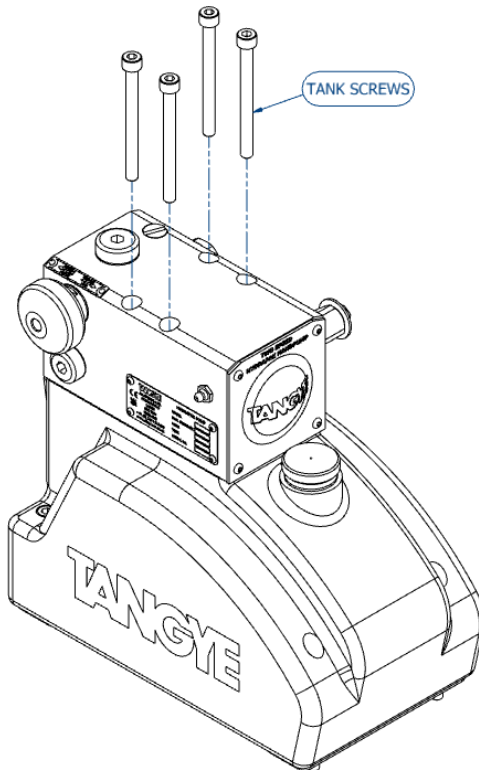

Figure 1 – Fastening Pump to Tank

6.2 Before Use

Check the fluid level of the reservoir being used.

If the Hydrapak is fitted to a Tangye reservoir, remove the filler plug (129954) and seal (129859A) and ensure that the tank is at least $\frac{3}{4}$ full. If more fluid is required, fill the reservoir by pouring fluid in to this hole.

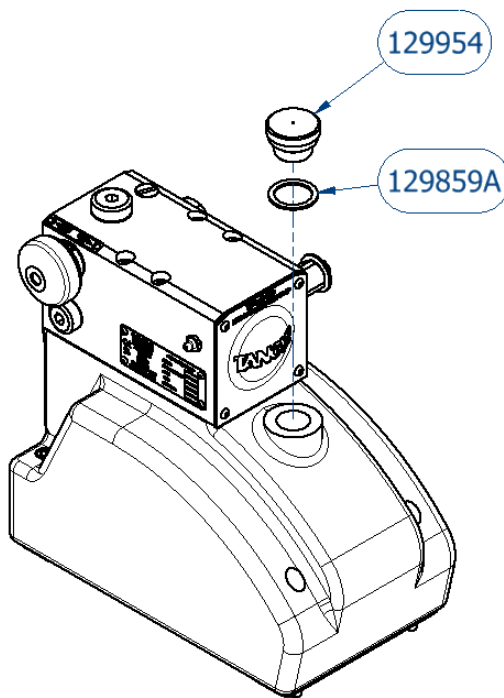

Figure 2 – Removing the Filler Cap

6.4 Operating Lever

The operating lever socket has a square broached hole, situated off the centre line of the handle axis. By turning the handle over, additional alternative positions are available.

Seven positions of lever engagement are possible, at intervals of 45°.

Insert the operating lever in to the optimal position and secure in place with the lever retaining washer (118234C) and retaining screw (32-66-0812).

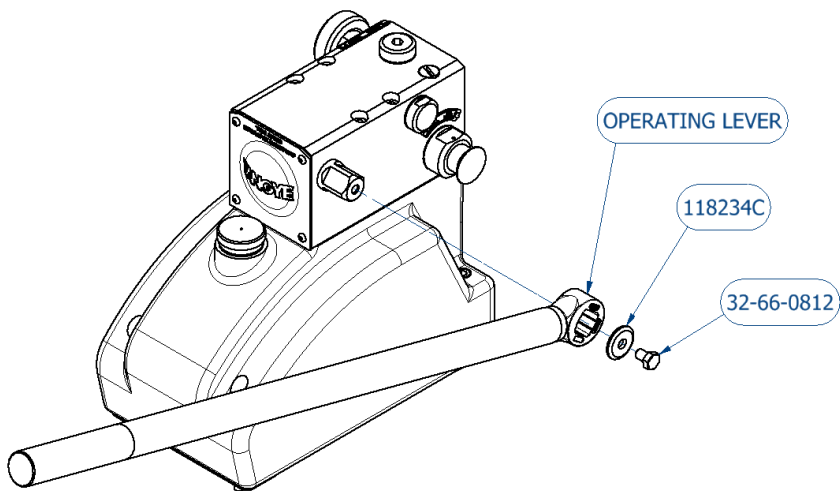

Figure 4 – Inserting the Operating Lever

6.5 Connecting the Output

There are two delivery connections positions, one on the front face and the other on the top face of the pump. Either one may be used but not both together. A delivery valve stopper is screwed into that connection not in use and as this locates the delivery valve cage in either position, it must always be fitted and on no account must a pressure gauge or any other connector be screwed in direct as an alternative.

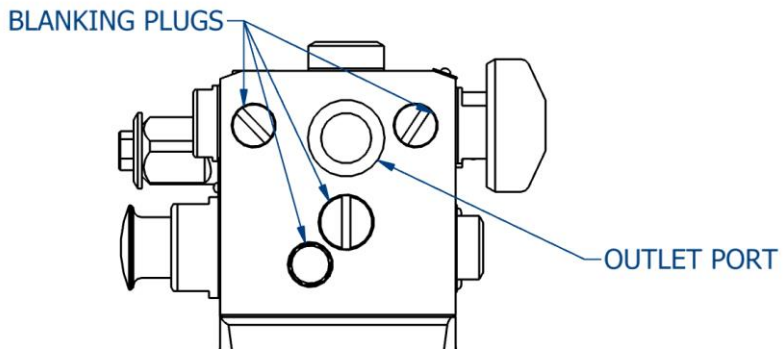

Figure 5 – Inserting the Operating Lever

6.6 Select Low Pressure

Ensure that the pump is in low pressure mode by pulling the pressure selector button out from the pump body.

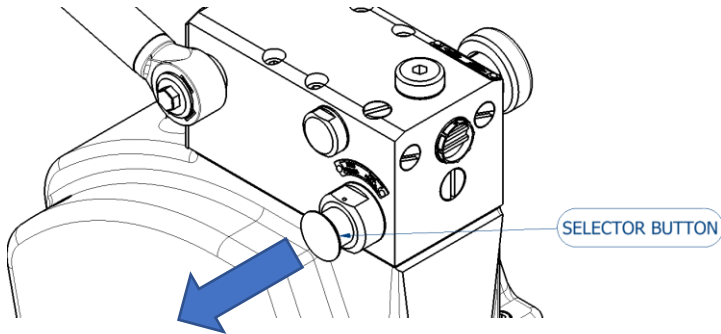

Figure 6 – Selecting Low-pressure Mode

6.7 Pump in Low Pressure Mode

The pump is now ready to be used in low-pressure mode. The flow rate of the pump is much greater than in high-pressure mode, so low-pressure mode should be used until high pressure is required.

Take care not to operate the pump when the oil in the cistern is low, as air may be drawn in and the system will have to be vented.

6.8 Select High Pressure

When the effort on the lever becomes excessive (pumping against a pressure over 52 bar), the pump should be changed over to high pressure.

To do this push the pressure selection button in towards the pump body until it is fully inserted. Do not apply effort on the operating lever whilst performing this changeover or you will prevent the push button from being pushed fully home.

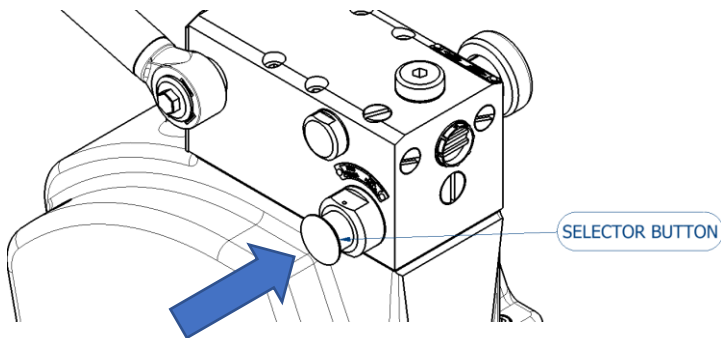

Figure 7 – Selecting High-pressure Mode

6.9 Pump in High Pressure Mode

The pump is now ready to generate high pressure. Push down on the operating lever to begin building pressure.

Warning- the pump generates dangerous high-pressure fluid! Make sure all warnings in Section 5 have been read, understood and followed.

6.11 Bleeding Air from the System

Air in the pump will cause loss of effective pumping stroke and will also permit high pressure to be raised even when the pressure selection button is in the low- pressure position. It is, therefore, essential to exclude all air to obtain the best performance.

If, after having vented the system, the pump continues to collect air, a systematic check should be made on all the seals of the suction side of the pump to ensure that they are not defective or loose.

Possible sources of air leakage into the pump are as follows;

- At the suction connection
- Releasevalve cagejoint washer.
- Releasevalve stem seal.
- Suction Filter Joint Washer.
- Pressure Selection Button Seal.

After charging the system with fluid, all air should be expelled, via an air vent at the highest point in the system by operating the pump on low pressure. The Hydrapak Pump may be operated in any position except one, i.e., on end with the front delivery connection downwards. When in this position it is not possible to expel all the trapped air and this will cause inefficiency.

6.12 Greasing the Rocker Shaft

Occasionally charge the rocker shaft bearing surfaces with a medium grade grease via the nipple provided.

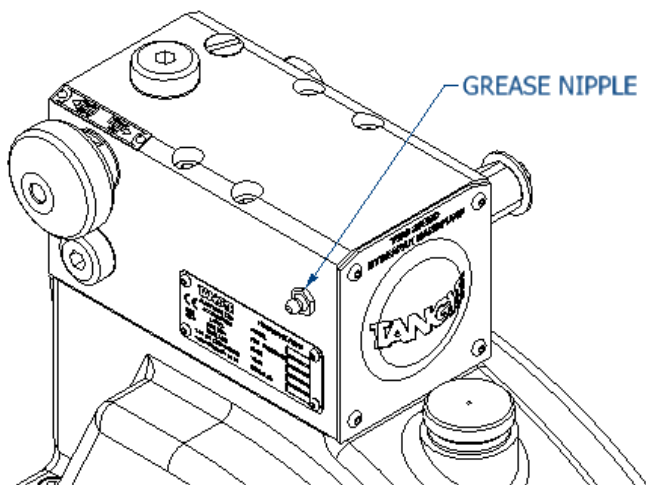

Figure 9 – Grease Nipple

6.13 Cleaning the Filter

Routinely clean the filter with cleaning fluid and dry off with air. Never dry the filter with a cloth!

Ensure that the release valve is closed (See Section 6.3) before removing the filter, otherwise the system will empty itself through the passageway.

Unscrew the filter anti-clockwise to remove.

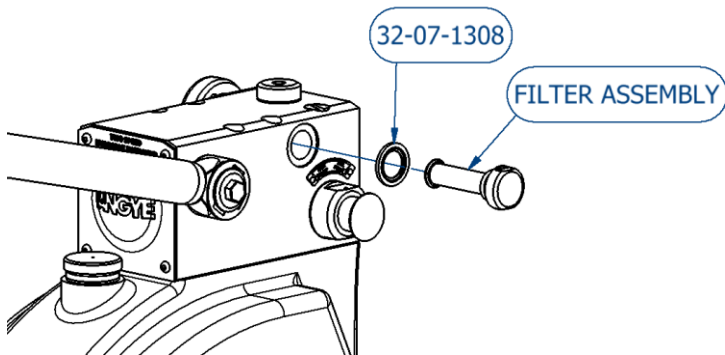

Figure 10 – Filter Removal

When reinserting the filter, ensure that the bonded seal (32-07-1308) is fitted between the filter head and the pump body.

After cleaning and replacing the filter, the pump should be bled (See Section 6.11).

6.14 Pressure Relief Valve

An optional, factory set pressure relief valve may be fitted to the pump and set at any specified pressure between 56 and 700 bar. We strongly recommend that all Hydrapak pumps are fitted with a pressure relief valve to prevent overloading and exceeding maximum safe working pressures. Please see Section 3 for details on how to order your pump with a relief valve.

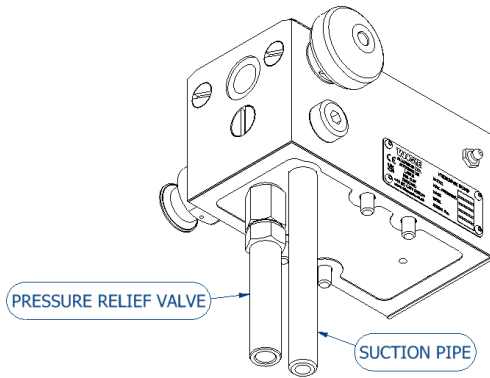

Figure 11 – Pressure Relief Valve

Alternatively, for retrospectively adding a relief valve to your pump, please see the table below.

Pressure Rating	Standard Relief Valve
1000 bar/14,500 psi	VPR0
700 bar/10,000 psi	VPR1
552 bar/8000 psi	VPR2
448 bar/6500 psi	VPR3
310 bar/4500 psi	VPR4
172 bar/2500 psi	VPR5
110 bar/1600 psi	VPR6

Table 1 – Relief Valves

6.15 Gauges

100mm gauges and a fixing kit are available for horizontal mounting of the pressure gauge above the top face of the pump. For pumps with a double acting valve, a fixing kit for vertical mounting is supplied.

Pressure Rating	Gauge Kit
1000 bar/14,500 psi	GHTK1000
700 bar/10,000 psi	GHTK700
552 bar/8000 psi	
448 bar/6500 psi	
310 bar/4500 psi	GHTK400
172 bar/2500 psi	
110 bar/1600 psi	GHTK110

Table 2 – Gauge Kits

7 After Use

Always open the release valve to ensure no residual pressure is left in the pump.

Always clean the pump after use.

Always remove the operating handle when not in use as this can cause a trip hazard if left in the pump.

Always ensure any oil spills are cleaned up after use.

7.1 Flushing/Draining the Pump

If the working fluid of the pump is water, then the system should be drained before storing.

Firstly, remove the filler plug as described in section 6.1, pour the fluid out of the tank and dispose of responsibly.

Next, remove any fittings from the delivery port shown in Section 6.5 so that the port is fully open. Operate the pump in low pressure mode (see Section 6.7) for 5 pumps to expel residual water. Note that this will expel water out of the outlet port, so stand clear and clean any fluid afterwards.

To remove any remaining moisture in the pump, remove the 1/8" BSP plug (766632) and bonded seal (32-07-0602) as shown in Figure 12.

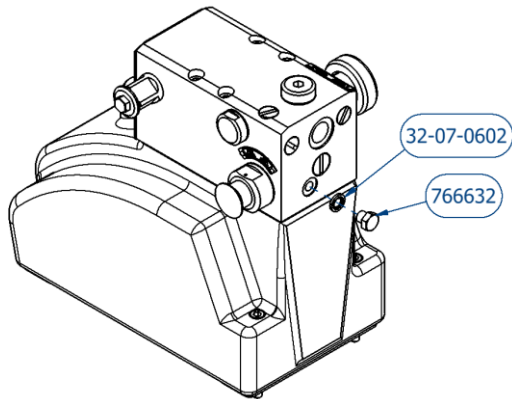

Figure 12 – Removing the Drain Plug

Tip the tank so that this port faces downwards to remove residual water. This port should then be connected to an airline and air blown. This will force any residual water back to the tank. Replace the plug and bonded seal afterwards.

To remove water from the high-pressure side of the pump, open the release valve as shown in Section 6.10. Connect this port to an airline and blow air in to the pump to force residual water back to the tank.

Finally, pour any remains of fluid out of the tank through the filler port and replace the filler plug as shown in Section 6.1.

8 Maintenance

As the pump can be used in a variety of different applications, the life time of the pump may vary. To prolong the life time, regular inspection of the pump should be undertaken.

In the normal course of service, no routine maintenance should be required, but attention to the following will assist in obtaining satisfactory service.

The oil level should be periodically checked; the reservoir should not be overfilled. Always use clean oil of the type specified in Section 2.2.

Regularly replace the fluid in the tank with clean fluid and wash the tank out as required.

Always wipe the claw/ram extension clean before retracting.

Inspect and clean ram and jack after every use, if subjected to abnormal or shock loading inspect for damage immediately.

Refer to the manufacturer or an authorised service centre for testing and service.

IMPORTANT – This pump should only be serviced by qualified personnel. If in any doubt please contact Allspeeds Ltd or a distributor.

IMPORTANT - Replacement parts must always be sourced from Allspeeds Ltd. The use of unofficial components will invalidate the warranty and may lead to damage or failure.

Most maintenance task can be carried out with standard tools.

All servicing operations should be carried out in a clean environment to prevent contamination of the oil and mating components.

Before carrying out any maintenance tasks ensure that the equipment is fully isolated and that there is no residual pressure in the system.

IMPORTANT – The hydraulic pump is a pressure vessel and should not be drilled, machined, mutilated or damaged in any way for mounting purposes or to assist in its removal for servicing, any warranty will be invalidated by such actions.

9 Parts List

9.1 Seal Kit Components

Each pump has a seal kit available and the kit required can be determined from Table 3.

Pump Range	Standard Seal Kit	EP Seal Kit
PHO0000	133953	134125
PHO1000	133952	134123
PHO2000	133951	134122
PHO3000	133950	134121
PHO4000	133949	134120
PHO5000	133948	134119
PHO6000	133947	133118

Table 3 – Seal Kits

10 Decommissioning

Major components are made from the following recyclable materials:

Description	Material
Body	Aluminium
Rocker	Mild Steel
Tank	Aluminium
High Pressure Plunger	Aluminium
Low Pressure Plunger	Stainless Steel

Table 4 – Part materials

Remaining components should be disposed of in accordance with local current regulations.

Hydraulic fluid should be drained into a suitable container and disposed of in accordance with current local regulations.