



Original Instructions

for

Hydramite Jacks

Revision 1 – Issue 2

(MOD 21219)

Allspeeds Ltd.

Royal Works, Atlas Street
Clayton Le Moors, Lancashire, UK.

BB5 5LW

01254 615100

Table of Contents

1	Scope	3
2	Technical Data	4
2.1	Jack Weights	4
2.2	Oil Requirements.....	4
2.3	Environmental Considerations	4
2.4	Noise and Vibration	4
3	Declaration of Conformity	5
4	General Safety Rules	6
4.1	Warnings.....	6
4.2	Important Information	6
4.3	General Safety	6
4.4	Warnings.....	7
5	Operating Instructions	8
5.1	Before Use	8
5.2	Check Oil Level.....	9
5.3	Positioning the Jack	10
5.4	Raising the Jack.....	12
5.5	Lowering the Jack	16
6	After Use	17
7	Maintenance	18
8	Parts List	19
8.1	Seal Kit Components.....	19
9	Decommissioning	20

1 Scope

This manual covers the operation and maintenance of the Hydralite range of Tangye hydraulic lifting jacks.

The Hydralite range are lightweight, moveable jacks designed to lift heavy loads with low effort and maximum safety. These jacks are not designed to be moved whilst under load.

These jacks are designed in accordance with BS EN 1494:2000 +A1 2008 – the British Standard for “Mobile or moveable jacks and associated lifting equipment”

Please read carefully and work in accordance with this instruction booklet and keep in a safe place for future reference.

It is the responsibility of the purchaser to ensure that operators are properly trained in the safe use of this equipment and have access to this document.

No modification and/or additions may be made to this equipment without the written permission of the manufacturer.

It is expected that the product is used by competent technical personnel who have been properly trained to use hydraulic lifting equipment.

2 Technical Data

2.1 Jack Weights

Important: Ensure the correct Manual Handling procedures are carried out when handling the jacks.

The weight of the jack is marked on the nameplate affixed to the top of the jack. Where a jack has a lifting handle, this should be used during transportation. Larger jacks may need to be moved by two people.

2.2 Oil Requirements

The Hydramite range of hydraulic jacks contain nitrile seals and should only be used with good quality hydraulic oil (e.g. Shell Tellus 32). For compatibility with any other fluid, please contact the manufacturer.



2.3 Environmental Considerations

The jack is intended for use in industrial environments, inside or outside, between temperatures of -20 to $+50^{\circ}\text{C}$. The jack should not be used outside these limits or in explosive atmospheres/areas of nuclear radiation.

2.4 Noise and Vibration

By its design, the jack operates slowly under manual effort. There is no noticeable noise or vibration. The noise level does not exceed 70 dB(A).

3 Declaration of Conformity

		<h2>DECLARATION OF CONFORMITY</h2>
Company name:	Allspeeds LTD	
Company address:	Royal Works, Atlas Street, Clayton le Moors, Accrington, Lancashire BB5 5LW, UK	
Machinery covered by this declaration:	Description:	Hydraulic Jack
	Model:	Hydramite 8104H, 8105H, 8104HH, 1105002A, 1105028, 1105127, 1105133, 1105134, 1105148, 1105124, 1105130, 980328, 1105002, 1105125, 1105128, 980325, 980333, 980334, 105003, 1105126, 1105129, 1105132, 1105179
	Type:	Tangye Hydramite Jacks
The machinery conforms to all the requirements of the Machinery Directive 2006/42/EC.		
The machinery also conforms to the following Directives:	n/a	
The following standards have been applied:	BSEN1494:2000+A1:2008 (excluding 5.5.3.2 & annex B.1.1.g)	
The technical documentation is compiled in accordance with part A of Annex VII of the Machinery Directive 2006/42/EC		
Person authorised to compile the relevant technical documentation (based in the European Community):	Name:	Authorised Rep Compliance LTD.
	Address:	71 Baggot Steet Lower, Dublin, D02 P593, Ireland
The relevant authorised person undertakes to transmit, in response to a reasoned request by the national authorities, relevant information on the machinery. This information will be transmitted by: (email, post)		
Person authorised to make this declaration:	Name:	Keith Elliot
	Position in company:	Managing Director
	Signature :	
	Place of Declaration:	Accrington, Lancashire, UK
	Date of Declaration:	4 th January 2021

4 General Safety Rules

4.1 Warnings

These warning are provided to improve safety and should be carefully read before using or maintaining the equipment.

4.2 Important Information

It is vital that these instructions are available to the equipment users. It is also important that they are retained with the equipment if it is sold or transferred to another user.

Allspeeds LTD will not be held responsible for any damage to the equipment or personal injury resulting from unsafe use of the product, lack of maintenance or incorrect operation.

4.3 General Safety





To prevent the risk of injury, the jack should only be used by fully trained and competent operators.

- Make sure that all safety devices are in place and functioning correctly
- Make sure the working area is adequately lit and is free of any obstructions
- Only operate the jack in a safe working environment and not during poor weather conditions. (Do not operate during rain/lightning/excessive heat etc.)
- The jack should not be used for the lifting of persons

Recommended PPE for operation and maintenance includes safety shoes, safety glasses and gloves.

Any spilt oil may create a slipping or tripping hazard. Care must be taken around the work area.

4.4 Warnings

	
<p>General Hazard.</p> <p>Hydraulic tool with inherently dangerous moving parts.</p>	<p>Crushing Hazard</p> <p>Do not put hand between jack and object being lifted.</p>
	
<p>Tipping Hazard</p> <p>Ensure jack is on level, smooth surface to prevent tipping.</p>	<p>Lowering Hazard</p> <p>Do not place anything under jack while loaded unless mechanically locked.</p>

5 Operating Instructions

5.1 Before Use

- Visually inspect the jack to ensure that it is in good condition.
- Check the external surfaces for mechanical damage and/or oil leaks. If either is present do not use the equipment and have the jack serviced.
- Ensure that the external surfaces are dirt free.
- Ensure the work area is clear and free from obstructions.
- Ensure the operator can watch the lifting device and the load during all movements.

5.2 Check Oil Level

To check the oil level, lay the jack on its side with the filler plug facing upwards as shown in Figure 1. Remove the filler plug and ensure that there is no airspace beneath the plug.

If there is an airspace, then oil needs to be added. Ensure that the surrounding area is clean. Use high quality hydraulic oil such as Shell Tellus ISO 32 or equivalent.

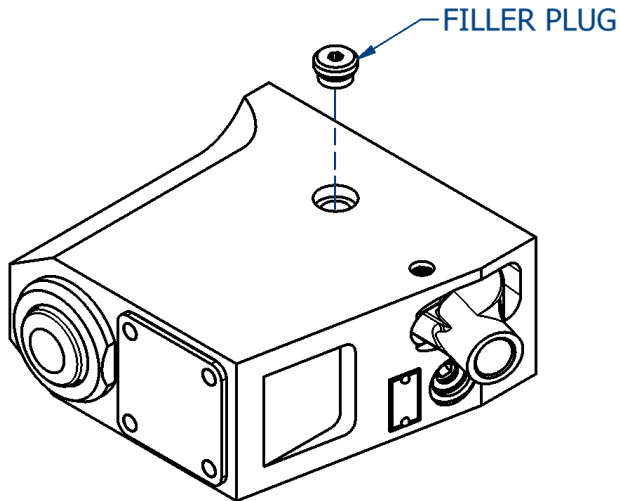

Figure 1 – Checking Oil Level

After checking the oil level, replace the filler plug.

5.3 Positioning the Jack

As the jack is a sealed system, it can be used in any mounting position.

IMPORTANT: Always ensure that the full base area of the jack is supported when in use.

Position the jack so that the load bears centrally on the top of the ram, ensuring that the load cannot touch any static part of the jack during lifting.

Always ensure that loads are applied centrally to the ram.

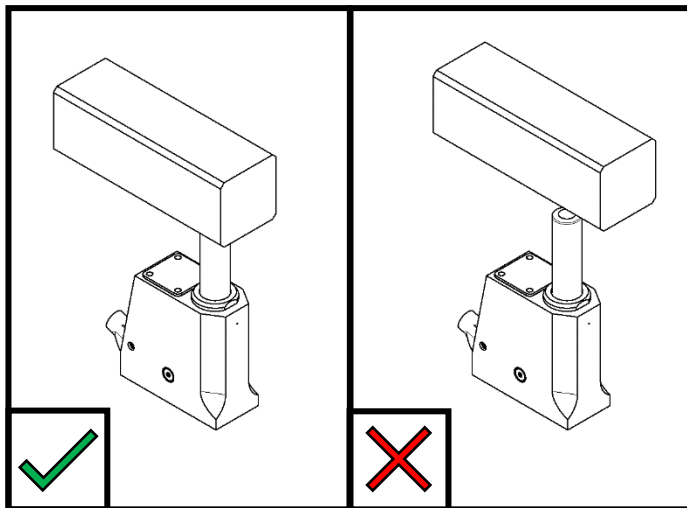

Figure 2 - Loading the Jack

Do Not position the jack by using the operating lever in the release valve. If the jack is to be placed some distance under the load, use the operating lever in the operating lever socket to position the jack.

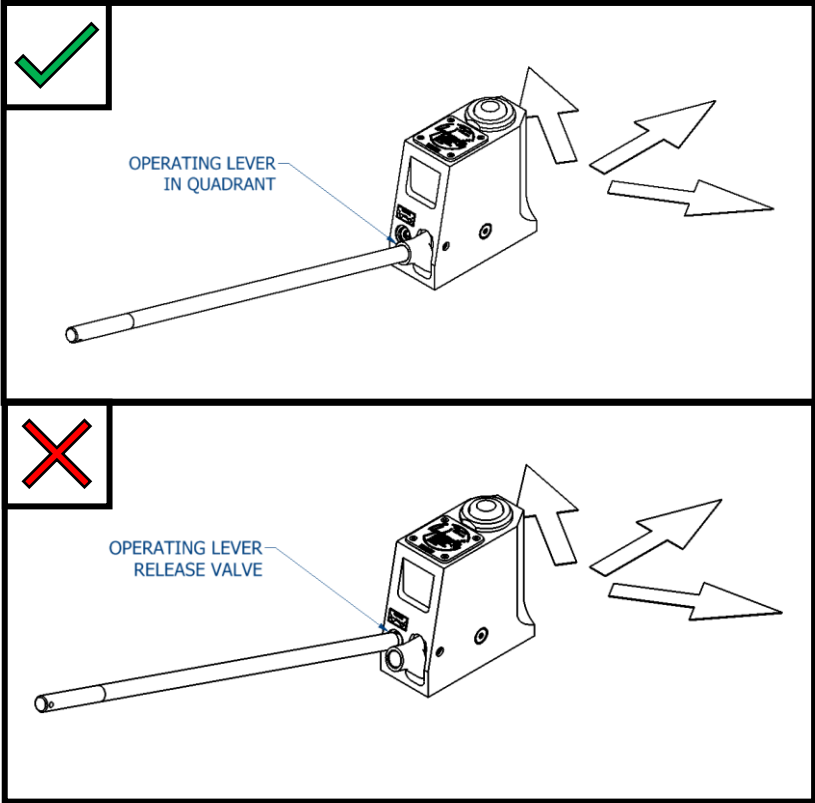

Figure 3 – Manoeuvring the Jack

5.4 Raising the Jack

The jack has an in-built hydraulic pump, which is worked by means of an operating lever, under the control of the operator.

The ram should only be extended hydraulically; it should never be pulled out by hand or used to carry the jack.

The permissible working load and the travel of the hydraulic jack is marked on the equipment.

5.4.1 Warnings

Do Not overload the jack especially when lowering loads.

Do Not under any circumstances go under a load when hydraulic jacks solely support it.

Do Not extend the ram by any means other than by pumping the jack.

Do Not attempt to exceed the rated load of the jack.

5.4.2 Tightening the Release Screw

Insert the ball on the end of the operating lever in to the hex of the release valve screw on the base of the jack as shown in the image below. Rotate clockwise until hand tight.

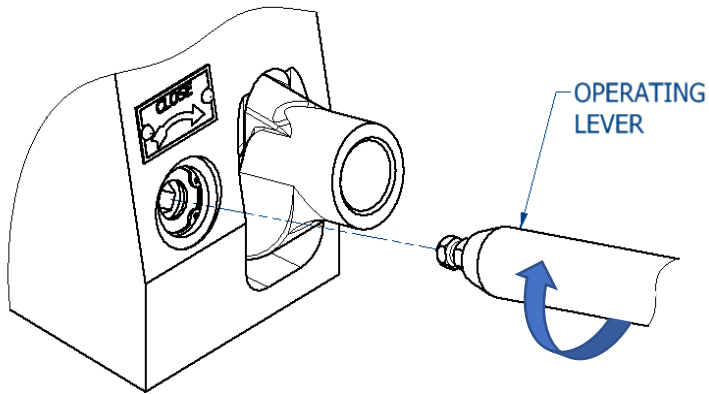

Figure 4 - Tightening the Release Valve Screw

5.4.3 Pumping the jack

Insert the operating lever fully in to the lever socket as shown in Figure 5.

The jack ram is raised on each downward stroke of the lever. The operating lever should be used in a steady controlled movement at a maximum of 30 strokes per minute.

When the full extension has been achieved a positive stop is engaged; further pumping will only circulate oil within the jack. This circulation will be apparent to the operator because

increased effort is necessary to move the operating lever. Do not continue pumping after this has been reached.

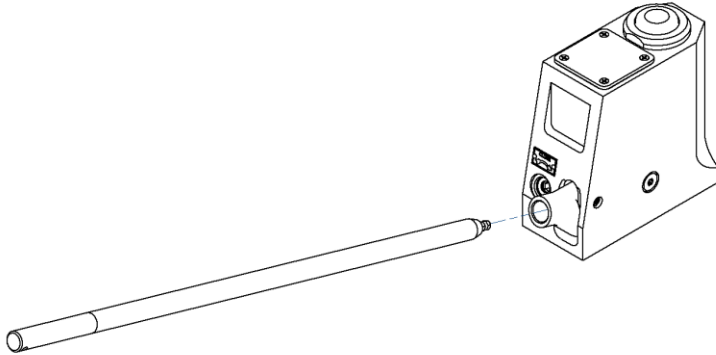

Figure 5 - Inserting the Operating Lever

The table below show the maximum effort required to operate the jack when loaded to the maximum rated load.

Jack Range	Max. Effort (kg)	Max. Effort (N)
6.5 Tonne	59.7	585.4
10 Tonne	57.4	562.5
15 Tonne	58.4	573

Table 1 - Maximum Effort on Operating Lever

Where the generated effort to raise the loaded jack exceeds 400N, the effort shall be lowered by additional persons.

5.4.4 Using Multiple Jacks

If using more than one jack, all the jacks must be able to individually raise the load e.g., two 10T jacks cannot be used to lift a 15T load as it is impossible to pump both jacks at exactly the same rate, or lower the jacks at exactly the same rate. One of the jacks will end up with an excess load and is liable to fail. In such case two 15T jacks should be used to raise a load of 30T.

When using multiple units to lift a load, all jacks **must** be operated at the same time, so that the load is lifted evenly.

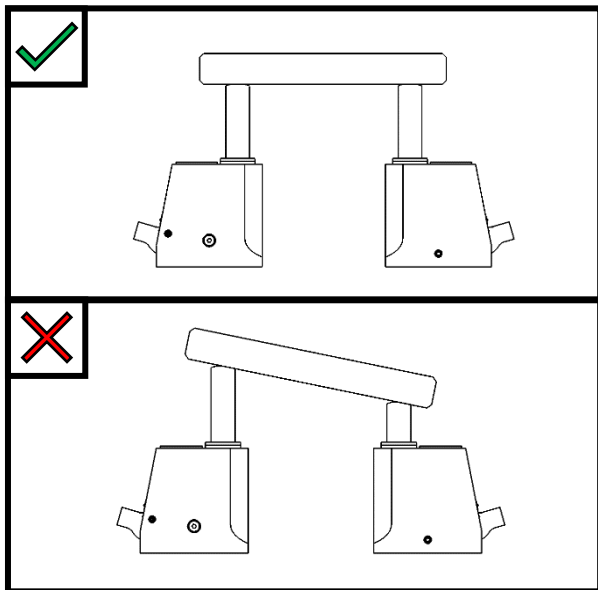

Figure 6 – Jacks Lifting Evenly

5.5 Lowering the Jack

Do Not drop loads onto the jack. If the jack is inadvertently subjected to a shock load, remove from service and have it checked by a competent examiner or service agent.

To lower the jack, first remove the operating lever from the operating quadrant and place it into the release screw.

Turning this anti-clockwise will allow the ram to descend. The amount this is rotated will control the speed of descent; only open a very small amount (approx. 5°) at first.

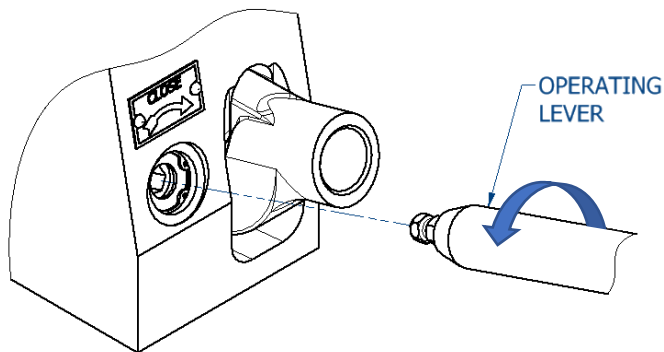

Figure 7 - Closing the Release Valve

6 After Use

After use, store the jack in an upright position with the ram fully descended and the lever socket in the 'up' position.

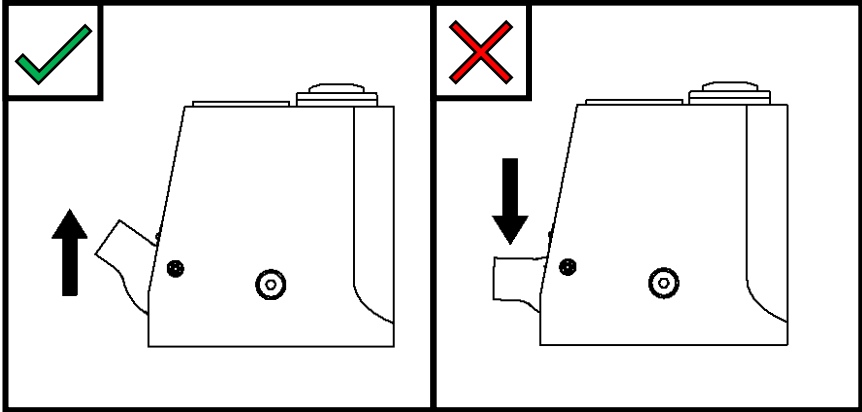

Figure 8 - Storing With the Lever Socket "Up"

Always close the release valve, to ready the jack for the next operation (see Figure 4).

Always clean the ram and retract after use.

Always remove the jack operating handle when not in use.

7 Maintenance

In the normal course of service, no routine maintenance should be required, but attention to the following will assist in obtaining satisfactory service.

The oil level should be periodically checked. Always use clean oil of the type specified in Section 2.2.

Inspect and clean ram and jack after every use, if subjected to abnormal or shock loading inspect for damage immediately.

Refer to authorised service centre for testing and service.

IMPORTANT – This jack should only be serviced by qualified personnel. If in any doubt please contact Allspeeds Ltd or a distributor.

IMPORTANT - Replacement parts must always be sourced from Allspeeds Ltd. The use of unofficial components will invalidate the warranty and may lead to damage or jack failure.

Most maintenance task can be carried out with standard tools.

All servicing operations should be carried out in a clean environment to prevent contamination of the oil and mating components.

Before carrying out any maintenance tasks ensure that the equipment is fully isolated and that there is no residual pressure in the system.

IMPORTANT – The hydraulic jack is a pressure vessel and should not be drilled, machined, mutilated or damaged in any way for mounting purposes or to assist in its removal for servicing, any warranty will be invalidated by such actions.

8 Parts List

8.1 Seal Kit Components

Each jack has a seal kit available and the kit required can be determined from Table 2.

Jack Model	Seal Kit
6.5 Tonne	995052
10 Tonne	995053
15 Tonne	995054

Table 2 – Seal Kits

9 Decommissioning

Major components are made from the following recyclable materials:

Description	Material
Body	Aluminium
Ram	Carbon Steel
Free Piston	Aluminium
Operating Lever	Carbon Steel

Table 3 – Part materials

Remaining components should be disposed of in accordance with local current regulations.

Hydraulic fluid should be drained into a suitable container and disposed of in accordance with current local regulations.