



Instruction Manual

for

Allspeeds Ltd.

Royal Works, Atlas Street
Clayton Le Moors, Lancashire, UK.
BB5 5LW

SL135 Softline Cutter

Allspeeds Product Code 980249

Allspeeds Document Revision 5 Issue 1

Date: 29/01/2024

Original instructions

Table of Contents

| | | |
|-----------|--|-----------|
| 1 | Introduction..... | 3 |
| 2 | Technical Data..... | 3 |
| 2.1 | Physical..... | 3 |
| 2.2 | Hydraulic Requirements..... | 3 |
| 2.3 | Environmental Considerations..... | 3 |
| 2.4 | Dimensions..... | 4 |
| 3 | CE Declaration of Conformity..... | 5 |
| 4 | UKCA Declaration of Conformity..... | 6 |
| 5 | General Safety Rules..... | 7 |
| 5.1 | Warnings..... | 7 |
| 5.2 | Important Information..... | 7 |
| 5.3 | Safety for Operation..... | 7 |
| 5.4 | Safety for Maintenance..... | 8 |
| 5.5 | Warning Symbols..... | 8 |
| 6 | Installation..... | 9 |
| 6.1 | Mounting Holes..... | 9 |
| 7 | Hydraulic Connections..... | 10 |
| 7.1 | Installing the Rope..... | 11 |
| 8 | Operating Instructions..... | 12 |
| 8.1 | Before Use..... | 12 |
| 8.2 | Extend the Blade (Cut Cycle)..... | 12 |
| 8.3 | Retract the Blade (Return Cycle)..... | 12 |
| 9 | Maintenance..... | 13 |
| 9.1 | Maintenance Notes..... | 13 |
| 9.2 | Maintenance Schedule..... | 13 |
| 9.3 | Remove & Replace Anvil..... | 14 |
| 9.4 | Remove & Replace Blade..... | 15 |
| 9.5 | Seal Detail..... | 17 |
| 10 | Parts List..... | 19 |
| 10.1 | Machined Components..... | 19 |
| 11 | Decommissioning..... | 20 |

1 Introduction

This manual covers the installation, operation and maintenance of a SL135 Softline wire cutter as Allspeeds part number 980249

This is a double acting, hydraulically operated tool suitable for cutting softlines and dyneema /aramid ropes up to 135mm (5.3") in diameter. It requires a dual line hydraulic supply (feed and return).

2 Technical Data

SL135 Softline cutter (part number 980249)

2.1 Physical

| | |
|--------------------------|-----------------------|
| Weight of SL135 in air | 34.5kg |
| Weight of SL135 in water | 23.5kg |
| Overall Dimensions | 951mm x 300mm x 155mm |

2.2 Hydraulic Requirements

| | |
|----------------------------|---------------------------------------|
| Cylinder Type | Double acting (feed and return ports) |
| Maximum Operating Pressure | 690 Bar (10,000 psi) |
| Swept Volume Cut Stroke | 0.40 Litre |
| Swept Volume Return Stroke | 0.30 Litre |

IMPORTANT – The maximum operating pressure stated above should not be exceeded during use of this tool. Ensure that all fittings and hoses used are suitable for use at this pressure and rated accordingly.

This SL135 is compatible with the following hydraulic fluids:

Good quality hydraulic oil (e.g. Shell Tellus 32, 68 or similar)

Water glycol (e.g. Castrol Transaqua HT2).

Ensure that the fluid used is cleaned to NAS Class 6 or better.

2.3 Environmental Considerations

This cutter should not be operated outside of the recommended temperature range of -5°C to +60°C.

This cutter is suitable for use subsea but should be regularly checked, cleaned and dewatered using a suitable dewatering spray.

2.4 Dimensions

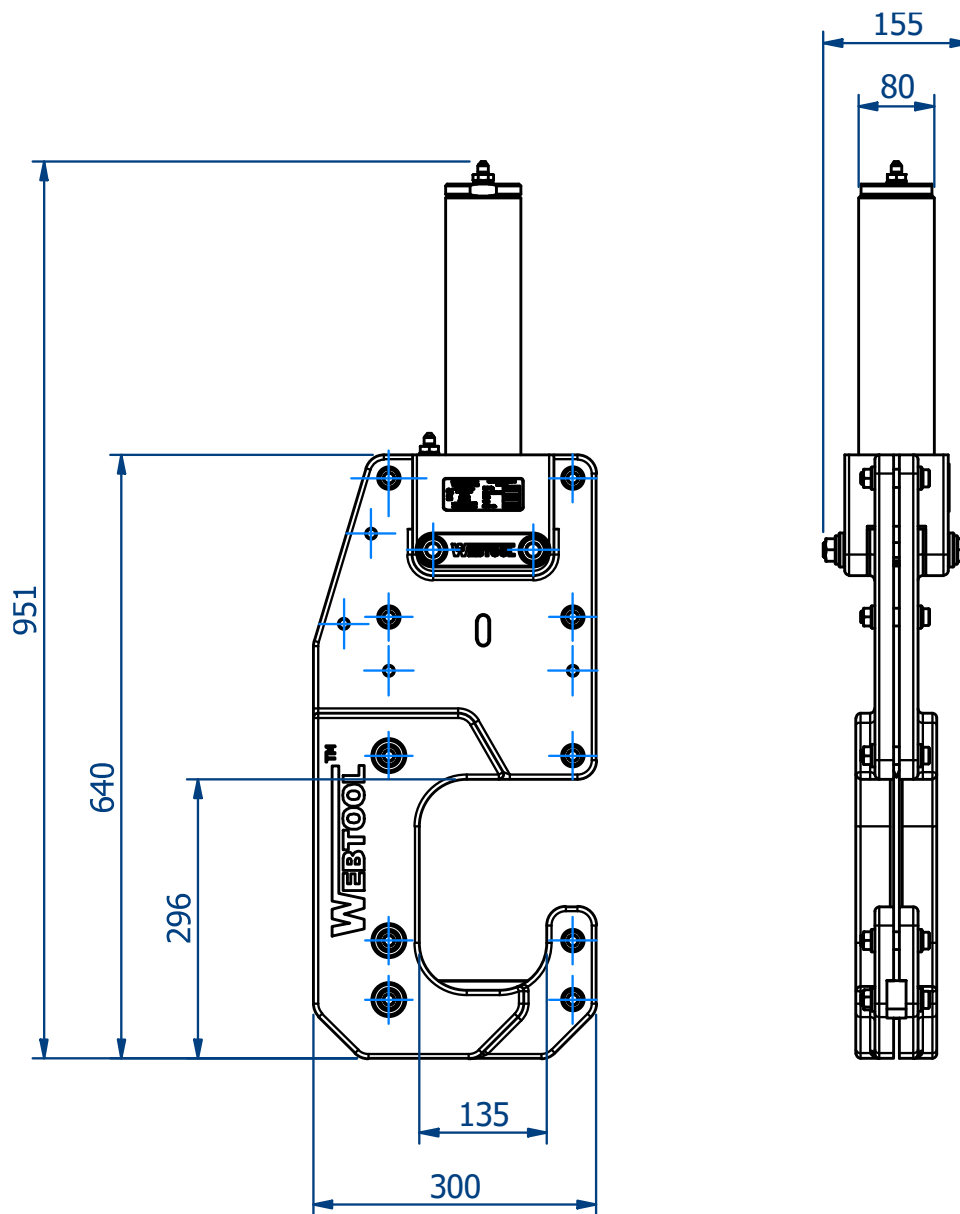

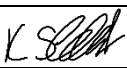

Figure 1 – Overall dimensions

3 CE Declaration of Conformity

| | | | |
|---|------------------------------|---|--|
|  | | <h2>DECLARATION OF CONFORMITY</h2> | |
| Company name: | | Allspeeds LTD | |
| Company address: | | Royal Works, Atlas Street, Clayton le Moors, Accrington, Lancashire BB5 5LW, UK | |
| Machinery covered by this declaration: | Description: | Webtool Softline Hydraulic Cutters | |
| | Model: | 980504, 980248, 980249, 980547 | |
| | Type: | SL55, SL80, SL135, SL165 | |
| The machinery conforms to all the requirements of the Machinery Directive 2006/42/EC. | | | |
| The machinery also conforms to the following Directives: | | N/A | |
| The following standards have been applied: | | N/A | |
| The technical documentation is compiled in accordance with part A of Annex VII of the Machinery Directive 2006/42/EC | | | |
| Person authorised to compile the relevant technical documentation (based in the European Community): | Name: | Authorised Rep Compliance LTD. | |
| | Address: | 71 Baggot Steet Lower, Dublin, D02 P593, Ireland | |
| The relevant authorised person undertakes to transmit, in response to a reasoned request by the national authorities, relevant information on the machinery. This information will be transmitted by: (email, post) | | | |
| Person authorised to make this declaration: | Name: | Keith Elliot | |
| | Position in company: | Managing Director | |
| | Signature: |  | |
| | Place of Declaration: | Accrington, Lancashire, UK | |
| | Date of Declaration: | 4 th January 2021 | |

4 UKCA Declaration of Conformity

| | | |
|---|--|--|
| UK CA | DECLARATION OF CONFORMITY | |
| Company name: | Allspeeds Ltd | |
| Company address: | Royal Works, Atlas Street, Clayton le Moors, Accrington, Lancashire BB55LW, UK | |
| Machinery covered by this declaration: | Description: | Webtool Softline Hydraulic Cutters |
| | Model: | 980504, 980248, 980249, 980547 |
| | Type: | SL55, SL80, SL135, SL165 |
| This machinery fulfils all the relevant provisions of the Supply of Machinery (Safety) Regulations 2008 (SI 2008/1597) as amended (SI 2011/2157, SI 2019/696). | | |
| The machinery also conforms to the following Directives: | N/A | |
| The following standards have been applied: | N/A | |
| This machinery must not be put into service until the machinery into which it is to be incorporated has been declared in conformity with the above standards and regulations. | | |
| Person authorised to compile the relevant technical documentation: | Name: | Chris Bond |
| | Address: | Royal Works, Atlas Street, Clayton le Moors, Accrington, Lancashire BB55LW, UK |
| The relevant authorised person undertakes to transmit, in response to a reasoned request by the national authorities, relevant information on the machinery. This information will be transmitted by: (email, post) | | |
| Person authorised to make this declaration: | Name: | Rory McGarry |
| | Position in company: | Technical Director |
| | Signature: | <i>R. McGarry</i> |
| | Place of Declaration: | Accrington, Lancashire, UK |
| | Date of Declaration: | 19/07/22 |

5 General Safety Rules

5.1 Warnings

These warnings are provided to improve safety and should be carefully read before installing, using or maintaining the equipment.

5.2 Important Information

It is vital that these instructions are available to the equipment users. It is also important that they are retained with the equipment if it is sold or transferred to another user.

5.3 Safety for Operation

IMPORTANT - This is an inherently dangerous piece of cutting equipment and is supplied without guarding. It is vital that the installer and end user perform a risk assessment and implement any safety features that they deem necessary and enforce a safe system of work before use.

To prevent the risk of injury, the cutter should only be used by fully trained and competent operators.

- Make sure that all safety devices are in place and functioning correctly
- Make sure the working area is free of any obstructions
- Check that all hydraulic hoses are in good condition
- Ensure that all operators are clear of the area before cutting commences

Recommended PPE for operation and maintenance includes safety shoes, safety glasses, ear defenders and gloves.

IMPORTANT - If the rope being cut is under tension there is the risk of it recoiling when severed. Ensure that all operators are out of the immediate area before operation.



Any spilt oil or trailing hoses may create a slipping or tripping hazard. Care must be taken around the work area. Energised hoses may move about during operation and should be fitted with whip-check devices to contain them in case of a burst.

5.4 Safety for Maintenance

Repairs carried out by untrained or unauthorised personnel may result in personal injury or serious malfunction of the tool.

Ensure that the SL135 is isolated from and free of hydraulic pressure before any maintenance is carried out.

5.5 Warning Symbols

| | |
|--|---|
|  | <p>General hazard. Hydraulic cutting tool with inherently dangerous moving parts. Please read and understand this manual to avoid the risk of injury.</p> |
|  | <p>Cut or severing hazard due to the cutting blade.</p> |

6 Installation

6.1 Mounting Holes

The cutter body contains a number of mounting holes, as shown on the drawing below:

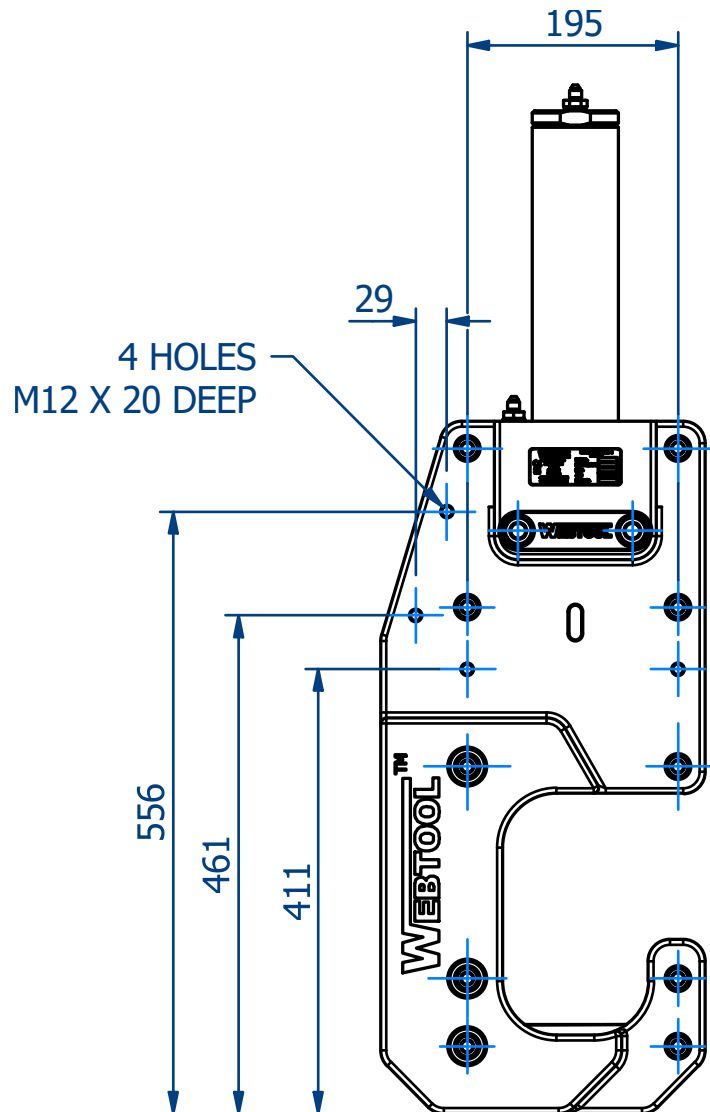

Figure 2 – Mounting holes

Ensure that the SL135 is securely mounted at multiple points.

7 Hydraulic Connections

The SL135 contains a double acting hydraulic cylinder and should be connected to a suitable hydraulic supply (not supplied).

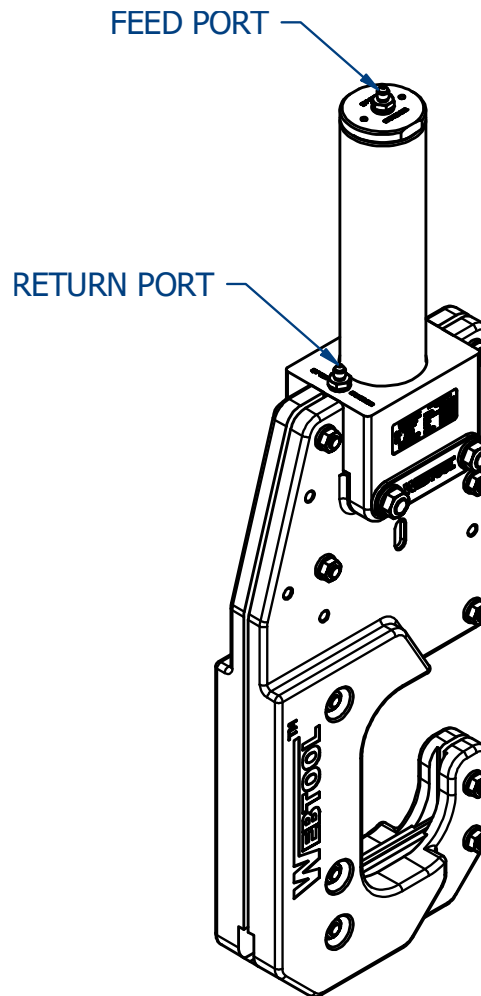

Figure 3 – Hydraulic ports

The feed port is 1/4" BSP female and fitted with a 1/4" to 7/16" JIC male/male adaptor.

The return port is 1/4" BSP female, and fitted with a 1/4" to 7/16" JIC male/male adaptor.

It is the responsibility of the end user to ensure that a suitable hydraulic supply is installed. It is recommended that a relief valve should also be incorporated in the return line to prevent excessively high pressures in the annular side of the hydraulic cylinders should the return to tank become blocked for any reason.

7.1 Installing the Rope

The cutter is designed to hook onto the workpiece during normal operation.

Before operation ensure that the rope is correctly positioned as seen in Figure 4.

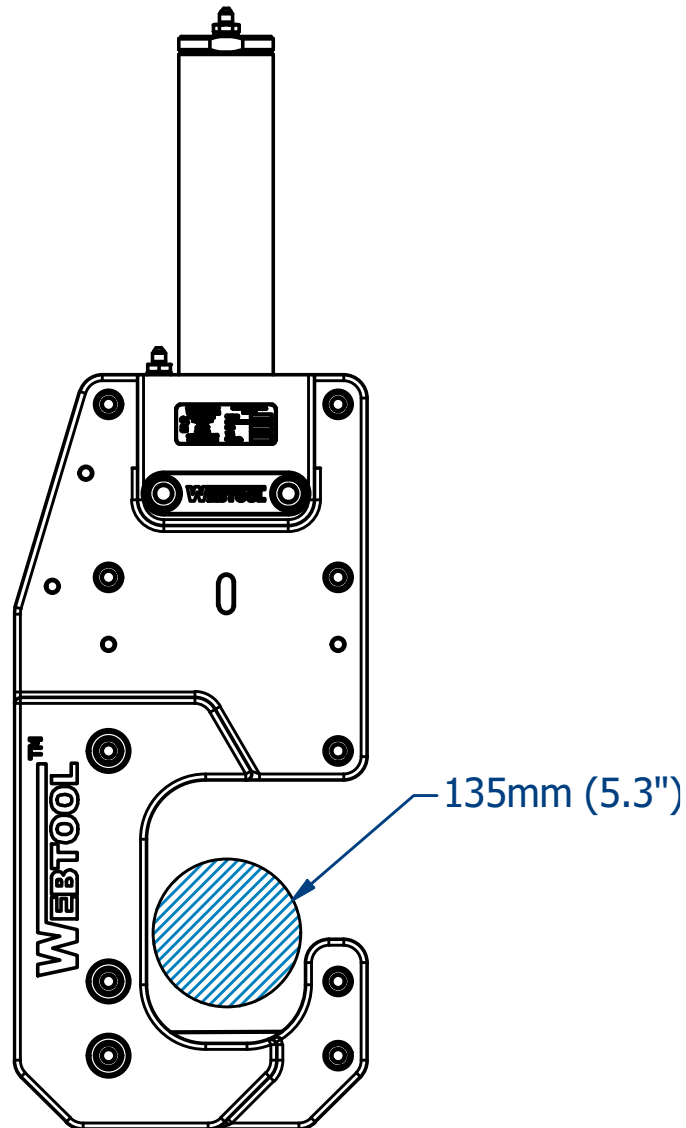

Figure 4 – Rope position

8 Operating Instructions

8.1 Before Use

With the hydraulic supply isolated, check the following parts of the cutter:

| Item | Procedure |
|----------------------------------|-----------------------------|
| Check the condition of the anvil | As described in section 9.3 |
| Check the condition of the blade | As described in section 9.4 |

Before use of the tool, ensure that all operators are at a safe distance from the cutter, and that any guarding or safety features are installed and operational.

Check that the hydraulic supply is set to a maximum of 690 bar (10,000psi) as stated in section 2.2.

8.2 Extend the Blade (Cut Cycle)

To extend the blade, pressurise the feed port whilst ensuring that the return port is open to tank. Do not exceed the maximum operating pressure.

8.3 Retract the Blade (Return Cycle)

To retract the blade, pressurise the return port whilst ensuring that the feed port is open to tank. Do not exceed the maximum operating pressure.

9 Maintenance

It is unlikely that service would be required on the hydraulic piston of the tool under normal circumstances, but a seal spares kit is available (995158) and it is recommended to stock this at all times.

The only parts that would need intermittent replacement would be the anvil and blade depending on the frequency of use, materials being cut and the corrosive conditions present during operation.

9.1 Maintenance Notes

IMPORTANT – This cutter should only be serviced by qualified personnel. If in any doubt please contact Allspeeds Ltd or a distributor.

Most maintenance task can be carried out with standard tools.

All servicing operations should be carried out in a clean environment to prevent contamination of the oil and mating components.

Care should be taken with all mating areas, including threads and sealing faces, as any damage or abrasive contamination could cause galling or seizing on re-assembly. Please note a suitable anti-galling paste should be used (we recommend Swagelok Silver Goop) on all stainless steel threads.

The cylinder (728112) is a pressure vessel and should not be drilled, machined, mutilated or damaged in any way for mounting purposes or to assist in its removal for servicing, any warranty could be invalidated by such actions.

The use of a Stilson wrench to remove the cylinder is not recommended as damage will occur.

Before carrying out any maintenance tasks ensure that the equipment is fully isolated and that there is no residual pressure in the system.

9.2 Maintenance Schedule

This tool requires the following operations or service tasks to be completed as listed:

| Task | See section | Frequency |
|--|-------------|---|
| Visual inspection of blade and anvil | 9.3, 9.4 | 14 days or after cut, whichever is soonest. |
| Function test (extend and retract ram) | 8.2, 8.3 | 14 days |
| Clean and dewater | | 7 days |
| Replace blade | 9.4 | As required |
| Replace anvil | 9.3 | As required |
| Replace seals | 9.5 | 12 months |

Table 1 – Maintenance schedule

9.3 Remove & Replace Anvil

The anvil will show an indent where the blade contacts it during a cut, but can be reused. Any excessively damaged or worn anvil should be replaced as described below.

Ensure that the blade is retracted before removing the anvil. This is as described in section 8.3.

You will require a 19mm spanner to remove the bolts (758078) to gain access to the pins (035146).

Slide the anvil (761299) out of the opposite side of the cutter.

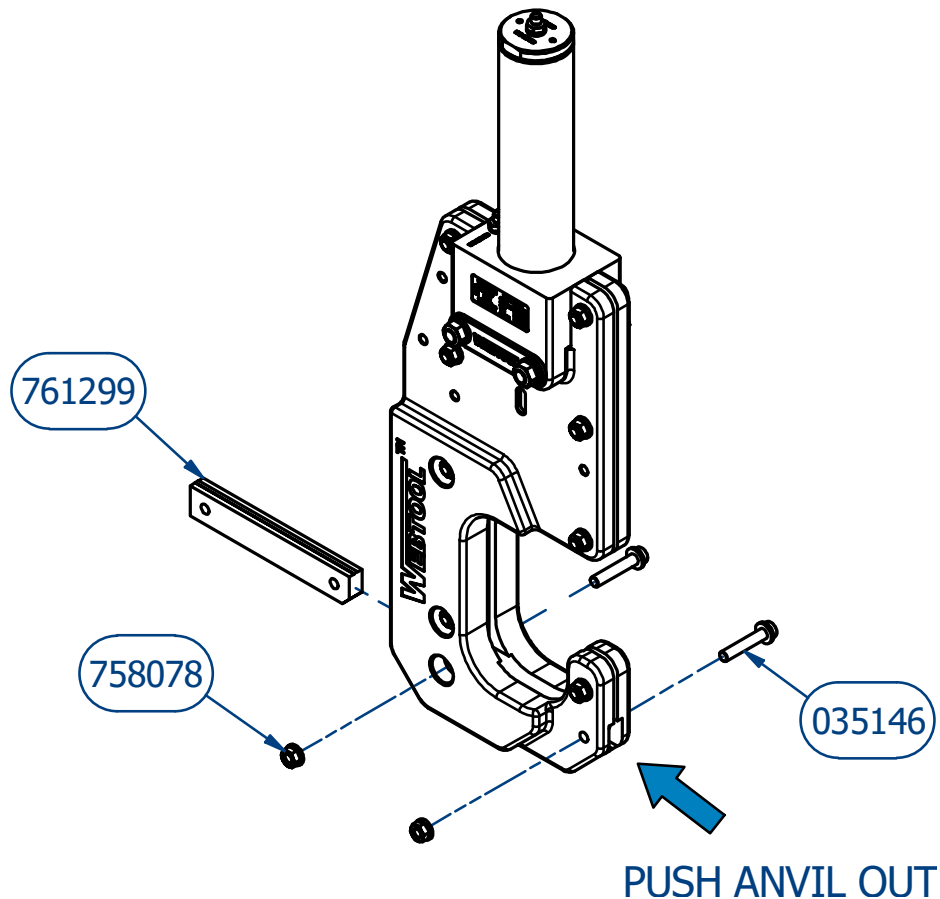

Figure 5 – Anvil removal/replacement

Anvil replacement is the reverse of the disassembly procedure. Ensure that bolts are correctly put back to ensure the anvil is secure for future use.

9.4 Remove & Replace Blade

IMPORTANT - The cutting edge is sharp, extreme caution and care should be taken when checking it. Wear suitable gloves when handling the blade.

IMPORTANT - Ensure that the hydraulic supply is isolated before proceeding.

The blade edge should be regularly checked to ensure that it is sharp and damage free.

The blade will need to be retracted slightly until the screw is visible through the access port as seen on Figure 6.

Remove the blade screw (PT00609). At this stage the blade is now unsupported and free to move. Do not put your hands in the mouth of the cutter as the sharp blade could fall and injure the user.

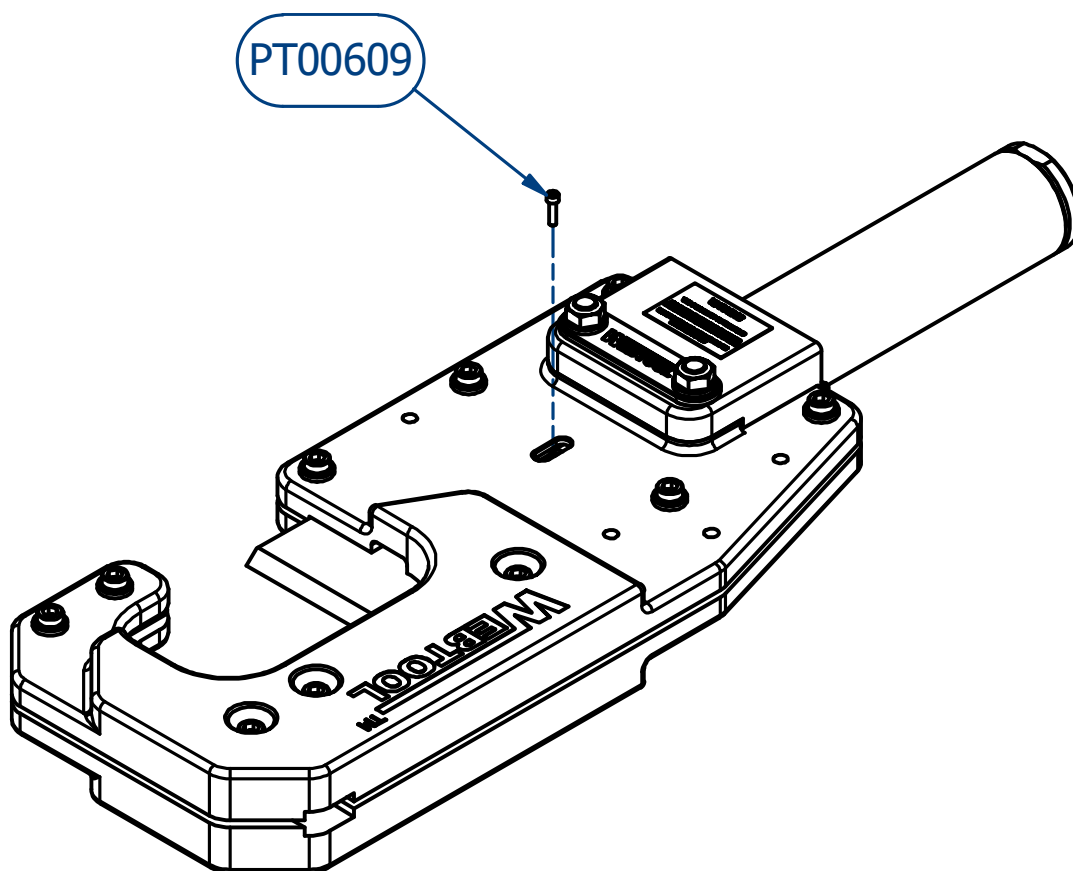

Figure 6 – Blade screw removal

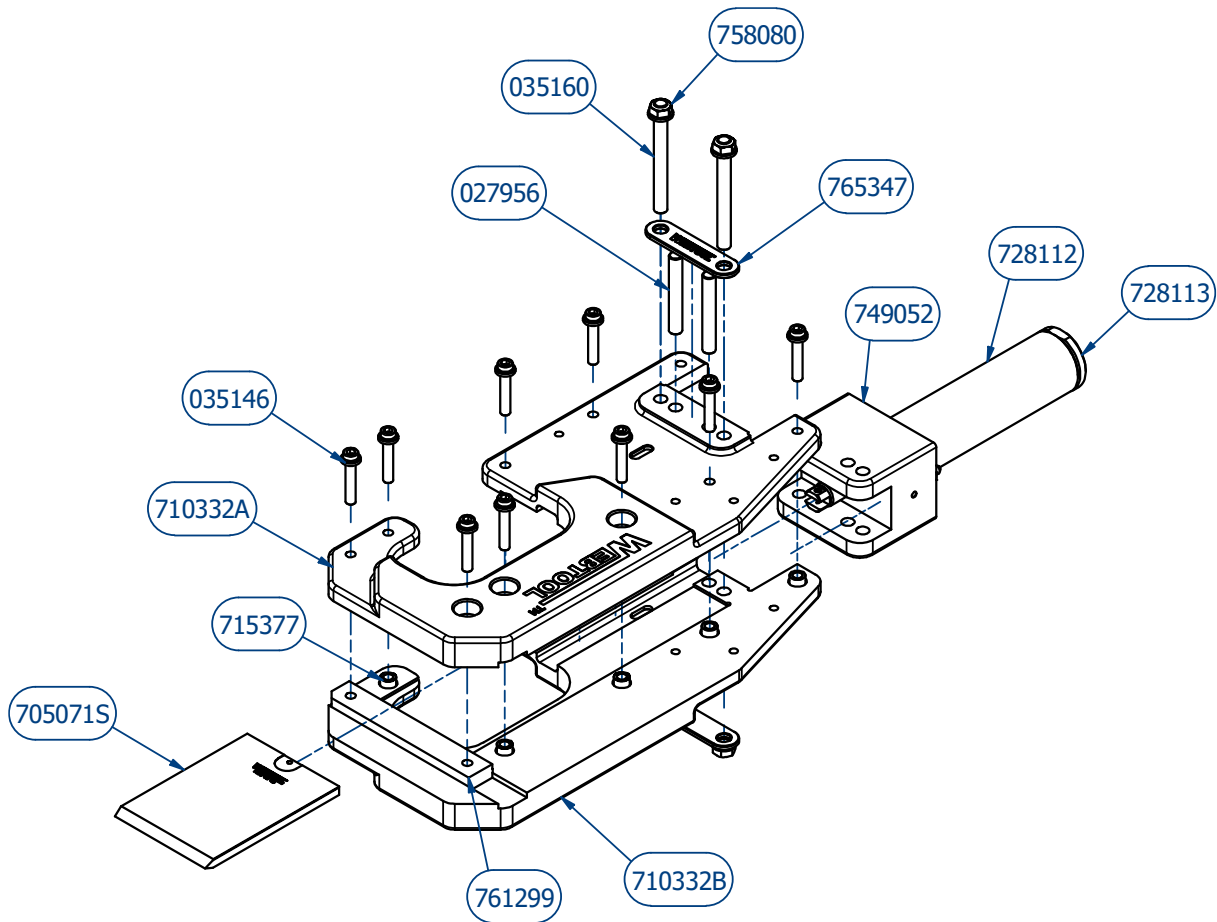

Figure 7 – Blade removal

Use spanner to remove 9 off bolts (035146) and 2 off bolts (758080). This then allows you to remove the cutter from the mounting plate (749052) and separate the body. The blade can now be removed.

Take care when handling the blade as it is very sharp.

Blade replacement is the reverse of the disassembly procedure.

9.5 Seal Detail

IMPORTANT - Replacement parts must always be sourced from Allspeeds Ltd. The use of unofficial components will invalidate the warranty and may lead to tool damage or system failure.

Removing or installing the ram can be done by placing the machined flats on the cylinder in a vice and rotating the cutters body on or off. Never use Stilsons or pipe clamps on the cylinder as damage may occur. If in doubt contact Allspeeds for advice.

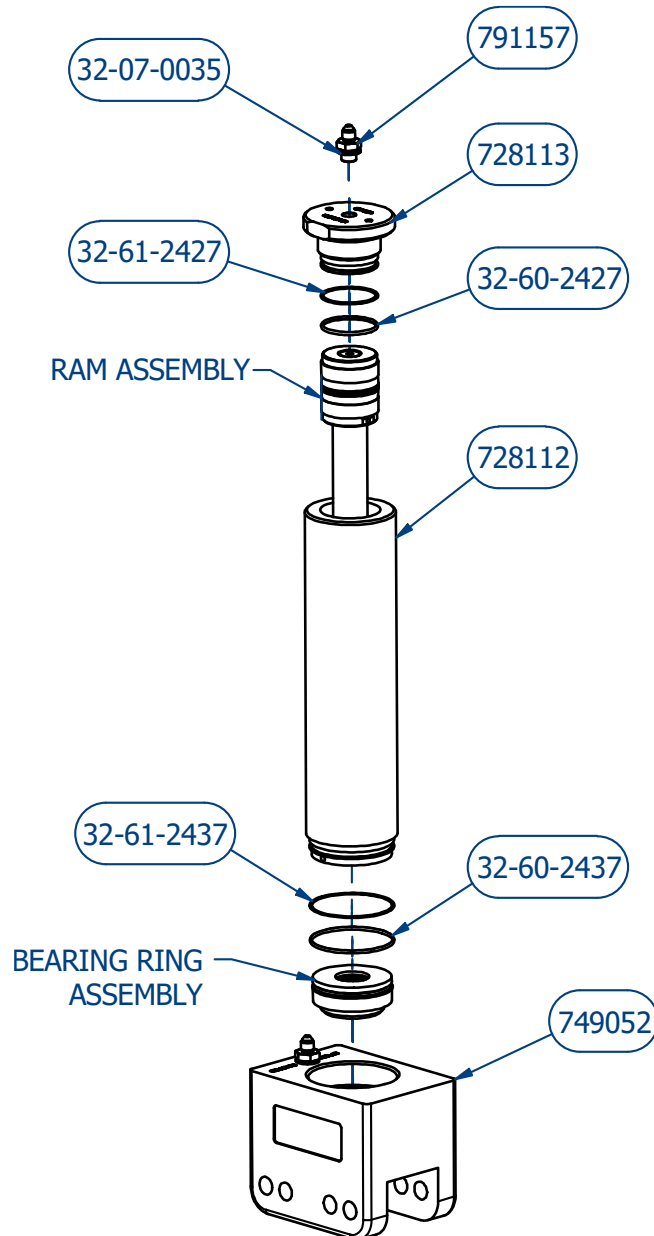

Figure 8 – Cylinder overall view

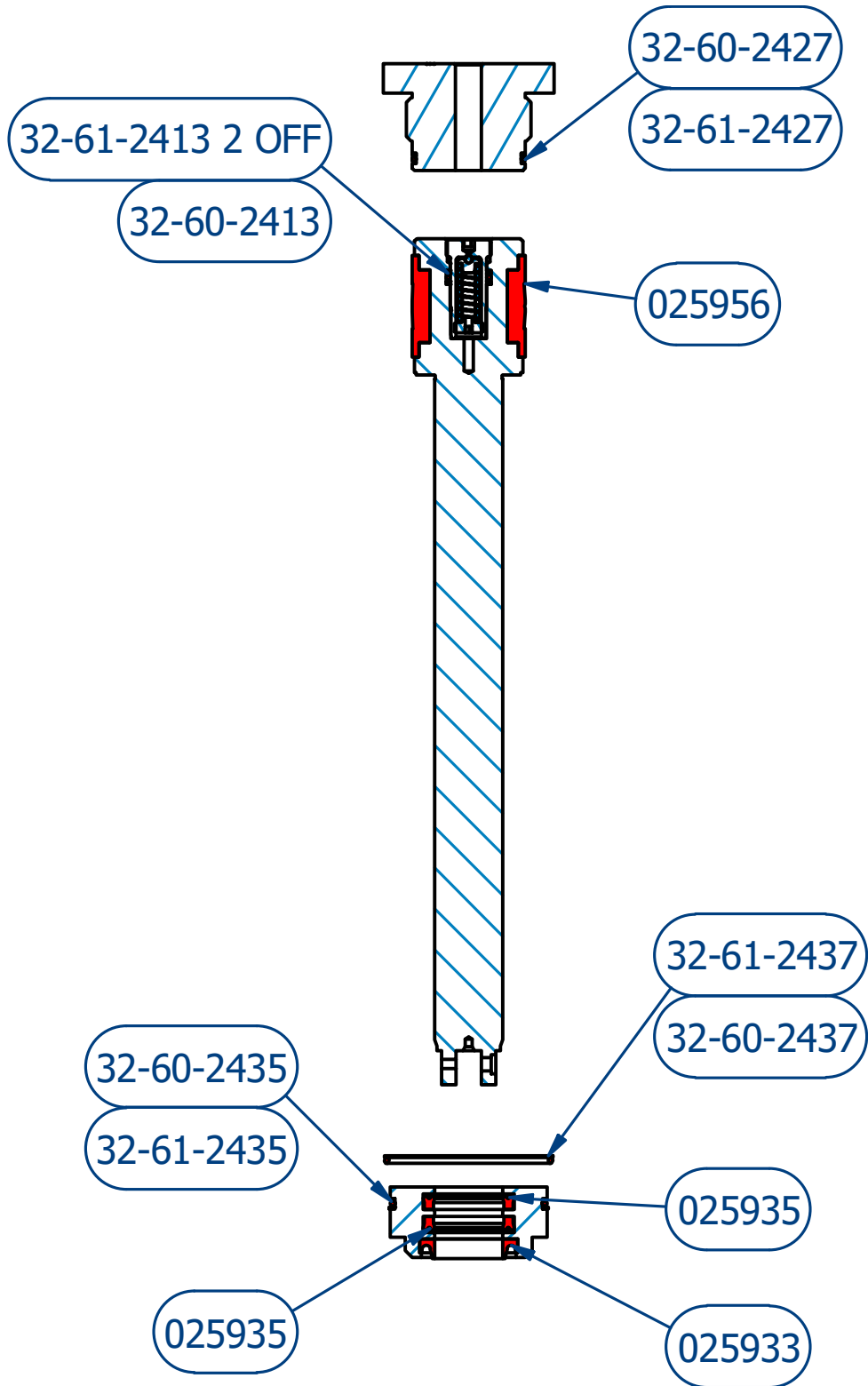

Figure 9 – Detailed seal view

10 Parts List

10.1 Machined Components

The cutter comprises the following components:

| PART NUMBER | QTY | SEAL KIT | DESCRIPTION |
|-------------|-----|----------|-----------------------------------|
| 710332A | 1 | | SIDE PLATE RIGHT HAND |
| 710332B | 1 | | SIDE PLATE LEFT HAND |
| 749052 | 1 | | HOUSING |
| 728112 | 1 | | CYLINDER |
| 774039 | 1 | | BEARING RING |
| 728113 | 1 | | CYLINDER CAP |
| 764153 | 1 | | PISTON |
| 761299 | 1 | | ANVIL |
| 025933 | 1 | X | WYCLIP WIPER SEAL |
| 32-60-2413 | 1 | X | RELIEF VALVE O-RING |
| 32-60-2437 | 1 | X | O RING |
| 32-61-2437 | 1 | X | BACKUP RING |
| 32-60-2435 | 1 | X | O RING |
| 32-61-2435 | 1 | X | BACKUP RING |
| 752569 | 1 | | PRESSURE WARNING LABEL |
| 025956 | 1 | X | PISTON SEAL |
| 32-60-2427 | 1 | X | O RING |
| 32-61-2427 | 1 | X | ANTI-EXTRUSION RING |
| 1155009 | 1 | | RELIEF VALVE |
| 704013 | 1 | | BALL 1/4" STAINLESS STEEL |
| 035167 | 1 | | CUP POINT SOCKET SCREW |
| 705071S | 1 | | BLADE |
| PT00296 | 1 | | WEBTOOL LARGE NAMEPLATE |
| PT00609 | 1 | | SOCKET HEAD CAP SCREW |
| 025935 | 2 | X | ROD SEAL |
| 32-61-2413 | 2 | | RELIEF VALVE A/E RING |
| 765347 | 2 | | RETAINING PLATE |
| 035160 | 2 | | TIE BAR |
| 027956 | 2 | | RETAINING PIN |
| 791157 | 2 | | COUPLING 1/4" BSP TO 7/16" JIC |
| 32-07-0035 | 2 | X | BONDED FACE SEAL |
| 758080 | 4 | | NUT, COLLAR SPECIAL M16 |
| 715377 | 8 | | SPACER |
| 035146 | 10 | | SCREW, FLANGED SPECIAL |
| 758078 | 10 | | NUT, COLLAR SPECIAL |

Table 2 – Parts list

Note – Items marked X are contained in seal kit. You can obtain this seal kit from Allspeeds LTD, part number 995158.

11 Decommissioning

Major components are made from the following recyclable materials:

| Part Number | Description | Material |
|--------------------|--------------------|------------------|
| 710332A 710332B | Side Plate(s) | Aluminium |
| 728112 | Cylinder | Aluminium bronze |
| 764153 | Piston | Stainless steel |
| 761299 | Anvil | Aluminium |
| 705071S | Blade | Tool steel |
| 774039 | Bearing Ring | Aluminium bronze |

Table 3 – Decommissioning

Remaining components should be disposed of in accordance with local current regulations.

Hydraulic fluid should be drained into a suitable container and disposed of in accordance with current local regulations.

Also available from Allspeeds



HTP - Hydrostatic Test Pump



- Hydrostatic test pump complete with tank, skid, handle & gauge
- Available in a range of pressures up to 1000 bar (14,500 psi)
- Relief valve fitted as standard
- Compatible with a range of fluid media
- Robust design
- Up to 1000 Bar working pressure
- High and low pressure stages with manual change
- Ideal for testing Webtool™ and other hydraulic products



HP690A – Hydraulic Intensifier



- The HP690 features a unique integrated safety circuit that automatically bleeds excess pressure caused by surfacing or temperature variation back to tank
- Compatible with 2 port hotstabs. No additional drain port is required
- Fitted with industry standard MiniBOOSTER™ intensifier
- All fittings rated to 690 bar (10,000 psi)
- Suitable for use at any water depth
- Compact unit – Fits into limited ROV payload space
- Aluminium and stainless steel construction – Corrosion resistant
- Robust Design – Pressure gauges are recessed into the body
- Dual pressure gauges – Input and output pressures can be accurately monitored

WEBTOOLTM

HYDRAULIC CUTTERS & SYSTEMS

CUTTING EDGE TECHNOLOGY

Webtool specialises in engineering powerful hydraulic tools for demanding environments and applications.

Our standard range of cutting, gripping and lifting tools for rope, cable and umbilical includes:

- Steel wire rope cutters up to 190mm diameter
- Cable, umbilical and flexible riser cutters up to 330mm diameter
- Softline cutters up to 165mm diameter
- Cable grippers up to 200mm diameter with 20 tonne lift capacity
- Emergency disconnection systems for both topside and subsea applications
- Long term subsea tools for deployment by R-ROV systems

APPLICATION SPECIFIC SOLUTIONS

Our experienced, in-house design and manufacturing team can quickly and efficiently develop a solution to suit your particular application. Contact us to discuss how we can help.

Allspeeds Ltd
Royal Works, Atlas Street
Clayton-Le-Moors, Accrington
Lancashire, BB5 5LW
United Kingdom

T: +44 (0)1254 615100

F: +44 (0)1254 615199

E: info@allspeeds.co.uk

W: www.allspeeds.co.uk