

HCV220 – Cable, Umbilical & Riser Cutter Part No – AS00045

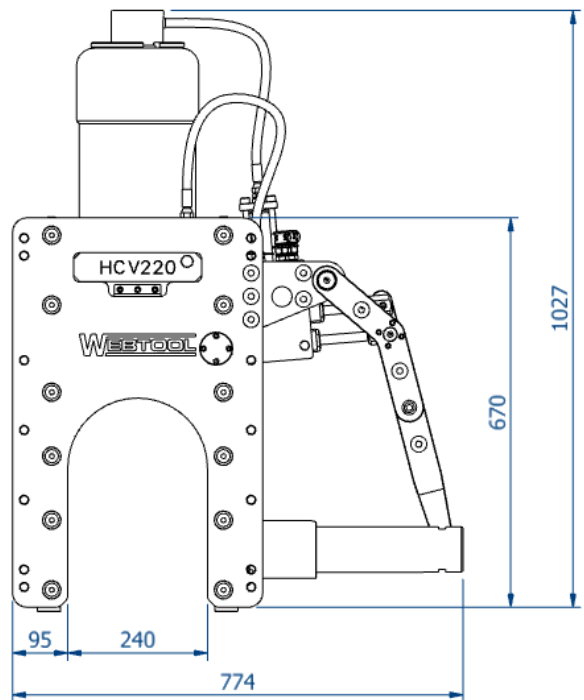
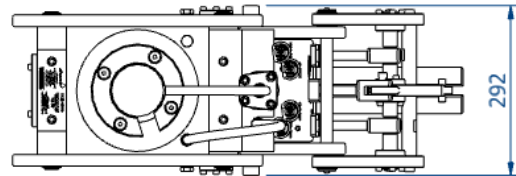

- Heavy duty cable, umbilical and riser cutter for use in severe working conditions
- Designed for subsea use, emergency disconnection as well as deck-mounted planned production cutting
- Hydraulically operated anvil for easy ROV deployment
- Robust steel construction with electroless nickel plating to resist corrosion
- Integrated interlock ensures that the blade cannot activate until the anvil is fully deployed
- Can be used at any water depth
- Cutting capacity – Maximum $\varnothing 220\text{mm}$
- Integrated hydraulic intensifier and internal filter and relief valve
- 210 bar maximum input pressure
- Approx weight in air – 320kg
- Approx weight in water – 276kg
- Swept volume cut stroke – 4.0 litres
- Swept volume return stroke – 2.0 litres
- Standard tool is shown above. Bespoke and custom designs to suit special applications are available on request

Webtool – A division of Allspeeds
Royal Works, Atlas Street
Clayton-Le-Moors, Accrington, Lancashire. BB5 5LW
UK Tel: +44 (0) 1254 615 100 Fax: +44 (0) 1254 615 199