

WCO22CL – Cut Loop Tool Part No - 980537

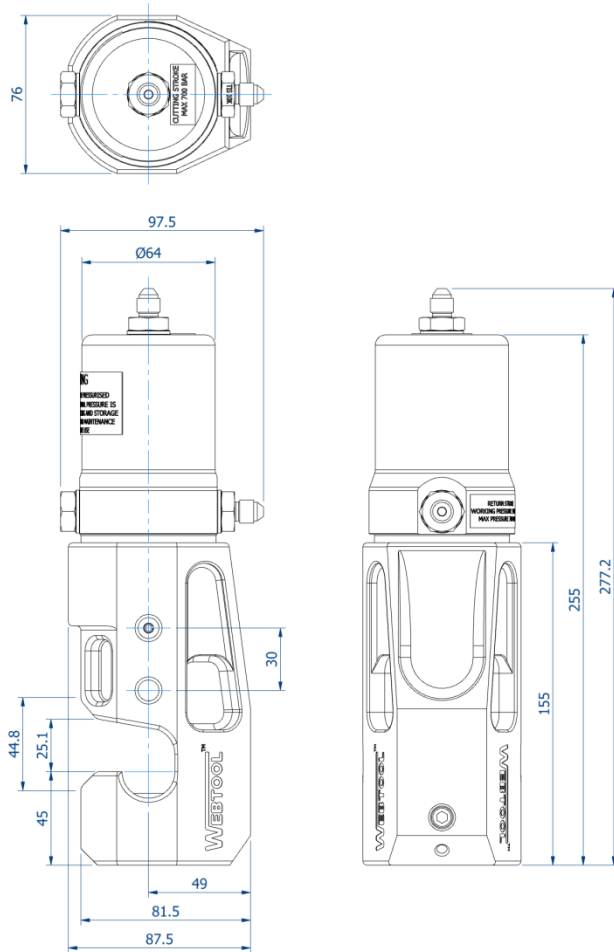

- Compact cutter designed for use on BOP Stack, EDP Stack & LRP Cutting Loops
- Open sided design with wide mouth allows for easy positioning of the tool on the Cut Loop
- Blade design optimised for cutting Stainless Steel Tube to relieve internal pressure
- Corrosion resistant stainless steel body with TiN coated stainless steel cylinder
- Long blade and anvil life ensures that tool maintenance is kept to a minimum
- Ideal for operation in confined spaces
- Optional hydraulic intensifier panel is available
- Optional handle is available
- 700 bar maximum input pressure
- Cutting Capacity on Stainless Steel Hydraulic Tubing (Cut Loop):
@ 210 Bar – Up to Ø9.525mm Tube
@ 700 Bar – Up to Ø20mm Tube
- Also suitable for cutting flexible hoses up to Ø22mm
- Supplied with 10k rated JIC No 4 fittings
- Approx weight in air – 7.15kg
- Approx weight in water – 6.23kg
- Swept volume cut stroke – 0.05 litres
- Swept volume return stroke – 0.04 litres
- Can be used at any water depth

Webtool – A division of Allspeeds
Royal Works, Atlas Street
Clayton-Le-Moors, Accrington, Lancashire. BB5 5LW
UK Tel: +44 (0) 1254 615 100 Fax: +44 (0) 1254 615 199