

## RCO54 - Wire Rope Cutter Part No - 980495

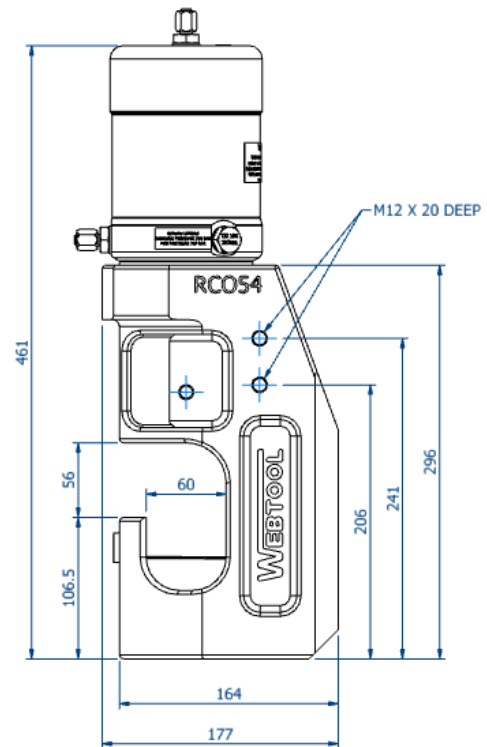
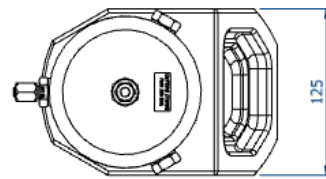

- Heavy duty wire rope cutter designed for use in severe working conditions
- Open sided design allows for easy positioning of the cutter on the cable
- Blade shaped anvil cuts higher grade cable
- Corrosion resistant stainless steel body with Nitrotec coated alloy steel cylinder
- Long blade and anvil life ensures that tool maintenance is kept to a minimum
- Ideal for operation in confined spaces
- Optional hydraulic intensifier panel is available
- Optional handle is available
- Can be used at any water depth
- Cutting Capacity - Steel wire ropes up to  $\varnothing 51\text{mm}$  (2") with a maximum tensile strength of  $1960\text{N/mm}^2$ . Individual wire strands must be a minimum of  $\varnothing 1.5\text{mm}$  (1/16")
- Suitable for cutting wire rope, cables and umbilicals
- 700 bar maximum input pressure
- Supplied with 10k rated JIC No 4 fittings
- Approx weight in air – 38kg
- Approx weight in water – 33kg
- Swept volume cut stroke – 0.45 litres
- Swept volume return stroke – 0.25 litres

**Webtool – A division of Allspeeds**  
Royal Works, Atlas Street  
Clayton-Le-Moors, Accrington, Lancashire. BB5 5LW  
UK Tel: +44 (0) 1254 615 100 Fax: +44 (0) 1254 615 199