

- **Versatile:** Perfect for deep sea operations or deck-mounted planned production cutting
- **Dependable:** Designed to cut the toughest armoured export cables and flexible production risers
- **Easy to use:** Hydraulically operated anvil for fast ROV deployment
- **Durable:** Engineered to last in the harshest of environments
- **Reliable:** Proven Webtool technology gives cutting edge performance
- **Powerful:** High output force ensures a successful cut
- **Low maintenance:** Long blade life ensures minimal servicing

Contact our engineering team to arrange cut trials or to discuss bespoke designs.

All products are made in the UK.

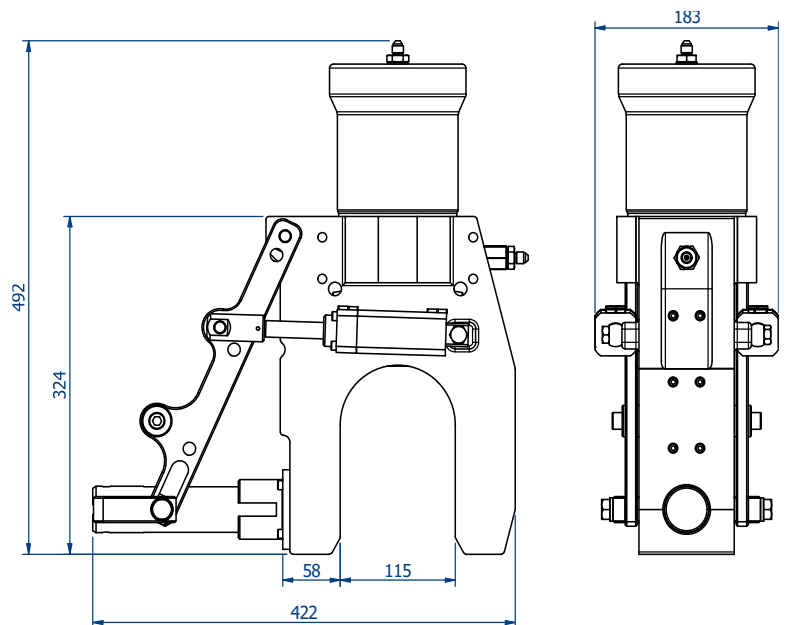
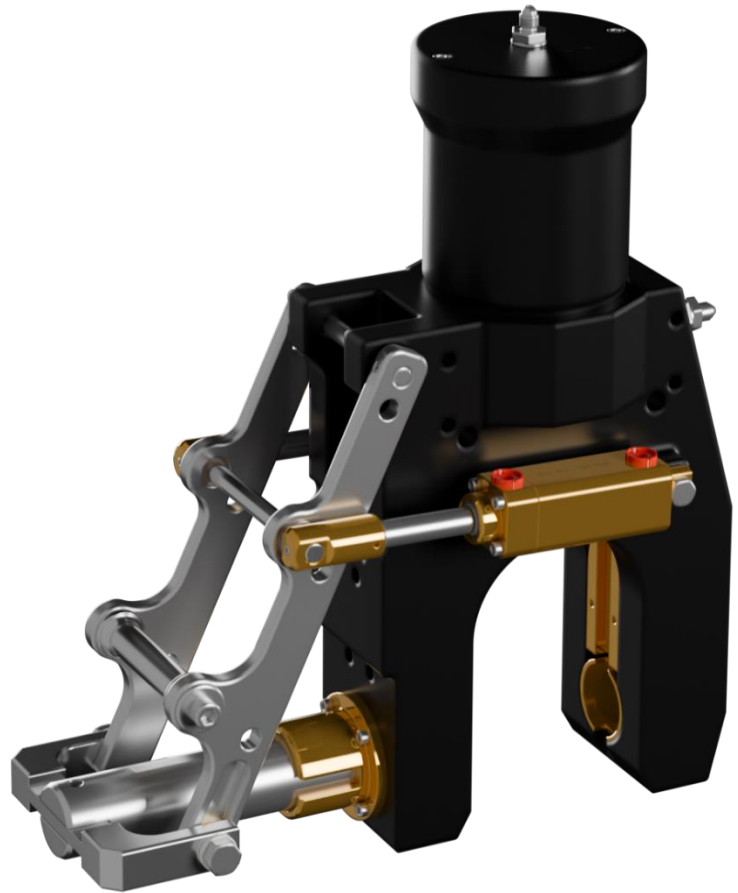

[www.allspeeds.co.uk](http://www.allspeeds.co.uk)

Webtool – A division of Allspeeds  
Royal Works, Atlas Street  
Clayton-Le-Moors, Accrington,  
Lancashire. BB5 5LW  
UK Tel: +44 (0) 1254 615 100  
Email: [info@allspeeds.co.uk](mailto:info@allspeeds.co.uk)

## Technical Specifications

- Maximum Ø100mm cutting capacity
- 640 bar maximum input pressure
- Approx weight in air: 29.5kg
- Approx weight in water: 22kg
- Swept volume cut stroke: 0.75 litres
- Swept volume return stroke: 0.4 litres

## Spare Parts and consumables

- Seal Kit (995291)
- Blade (705010C)
- Anvil (CC6378)

## Additional Extras:

### HP690A – Hydraulic Intensifier



Hydraulic panel with minibooster intensifier and additional safety circuits that prevent overpressure when returning to the surface. Available in a range of intensification.

### HTP – Hydrostatic Test Pump



Hydrostatic test pump complete with tank, skid, handle and pressure gauge. Perfect for testing any hydraulic equipment. Available in a range of pressures up to 1000 bar.

### Hydraulic Hoses



High quality hydraulic hoses to suit Webtool cutters or bespoke applications. Available in a range of pressure ratings and end fittings.