

## HCV100 – Electrical Cable, Umbilical and Riser Cutter - Part No 980292

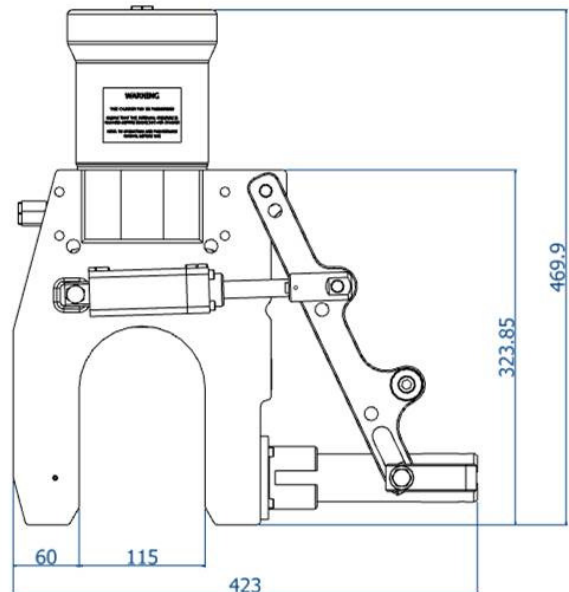
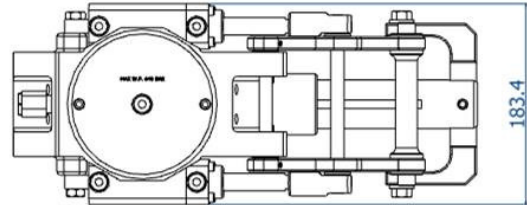

- Heavy duty cable, umbilical and riser cutter for use in severe working conditions
- Hydraulically operated anvil for easy ROV deployment
- Lightweight aluminium construction
- Long blade life ensures that tool maintenance is kept to a minimum
- Can be used at any water depth
- Optional intensifier panel is available
- Suitable for cutting electrical cables, hydraulic lines, riser and umbilicals

- Cutting capacity – Maximum  $\text{Ø}100\text{mm}$
- 690 bar maximum input pressure for main cylinder
- 210 bar max input pressure for anvil
- Approx weight in air – 29.5kg
- Approx weight in water – 22kg
- Swept volume cut stroke – 0.75 litres
- Swept volume return stroke – 0.4 litres
- Standard tool is shown above. Bespoke and custom designs to suit special applications are available on request

Webtool – A division of Allspeeds  
Royal Works, Atlas Street  
Clayton-Le-Moors, Accrington, Lancashire. BB5 5LW  
UK Tel: +44 (0) 1254 615 100 Fax: +44 (0) 1254 615 199