

RCV190 - Wire Rope Cutter Part No - 980230

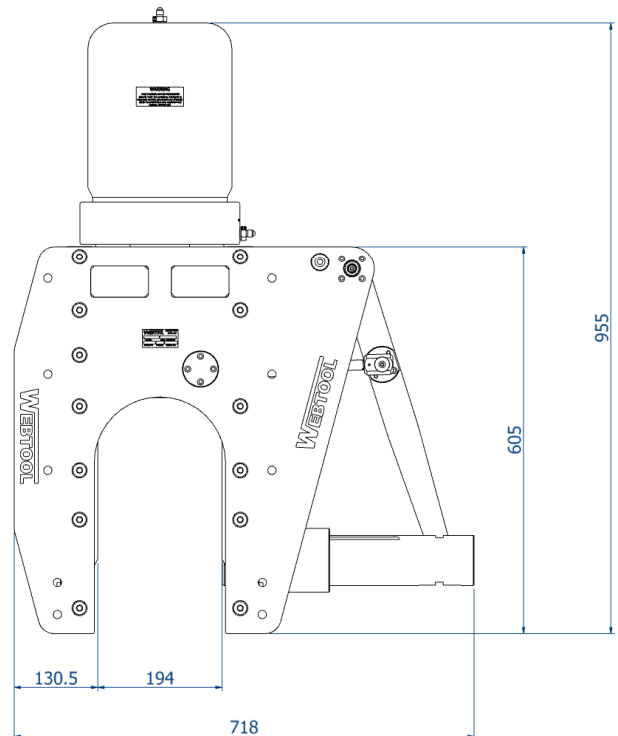
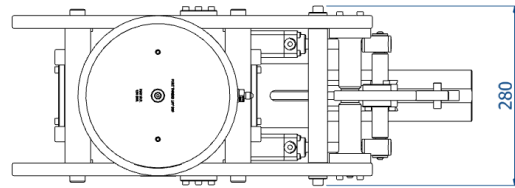

- Heavy duty wire rope cutter designed for use in severe working conditions
- Hydraulically operated anvil for easy ROV deployment
- Robust plated steel and stainless steel construction
- All steel components are electroless nickel plated to resist corrosion
- Long blade life ensures that tool maintenance is kept to a minimum
- Can be used at any water depth
- Optional intensifier panel is available
- Cutting capacity – Maximum $\varnothing 190\text{mm}$ wire rope of $1880\text{N}/\text{mm}^2$ grade
- Suitable for cutting wire rope, cables and umbilicals
- 690 bar maximum input pressure for main cylinder
- 210 bar max input pressure for anvil
- Approx weight in air – 297kg
- Approx weight in water – 256kg
- Swept volume cut stroke – 5.2 litres
- Swept volume return stroke – 1.4 litres
- Standard tool is shown above. Bespoke and custom designs to suit special applications are available on request

Webtool – A division of Allspeeds
Royal Works, Atlas Street
Clayton-Le-Moors, Accrington, Lancashire. BB5 5LW
UK Tel: +44 (0) 1254 615 100 Fax: +44 (0) 1254 615 199