



WEBTOOL[™]
HYDRAULIC CUTTERS & SYSTEMS

The cutting edge of nuclear
decommissioning and maintenance

allspeeds
www.allspeeds.co.uk

Webtool guillotine croppers offer several advantages over traditional 'pincer' or 'parrot beak' type croppers as they are capable of cutting through much larger cross-sections and are not prone to jamming, offering significant time savings.

Webtool guillotine croppers use a cold cutting process. The hydraulically powered tool comprises of a jaw containing a blade and an anvil. Operation is straightforward - position the metal section in the jaw, and activate the tool.

Our blades are not given to deflection or breakage and once the material is positioned in the cropper it cannot slip out as a result of the cropping action. A further advantage is our unique optional remote anvil and blade changing.

Unlike other cutting methods where there is a risk of the item flexing during cutting and either trapping or snapping the blade, closing the guillotine's anvil locks the component to be cut in position, ensuring the cut is completed successfully every time. For instance, the steel channels mentioned in the Sellafield case study are a good example of realising significant time savings. Each steel channel was cut within 2-3 minutes.

"A further advantage is our unique optional remote anvil and blade changing"

Sellafield Case Study

Webtool has supplied croppers to Sellafield Ltd for the removal of steel infrastructure from decanning bays previously used to store spent fuel rods and operational waste. The tooling package has significantly reduced the time and complexity of cutting steel sections during decommissioning operations.

In total 12 decanning bays adjacent to the main Pile Fuel Storage Pond are being decommissioned. The practicalities of cutting the steelwork as a series of multiple steel sections both above and below the water ruled out conventional cutting methods. Webtool supplied a guillotine cropper ideal for nuclear decommissioning capable of slicing through steel channels measuring up to 203 x 102mm (8" x 4").

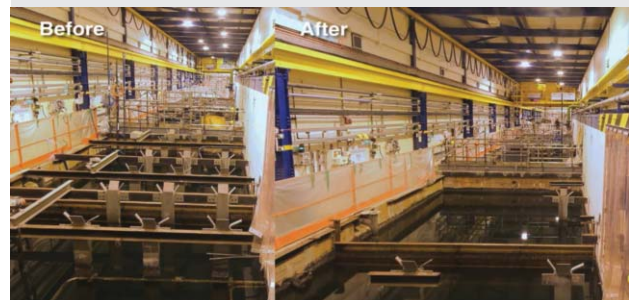

The Webtool guillotine action provides a clean cut with negligible waste, avoiding the swarf associated with using an angle grinder, for example. Weighing 235kg, the Webtool RCV215A tool includes a lifting frame designed to hold the tool in multiple positions and orientations. Once lowered onto the steel section, the tool's hydraulically activated anvil wraps around the steel section and the blade is deployed, completing the cut in seconds. A key operational benefit of the Webtool cutter is the minimal blade changes compared with using grinders and saws.

The complete Webtool steel section cropping package included the RCV215A (215mm guillotine cutter) and full lifting kit including slings, hydraulic pump, hoses and multi-position lifting frame allowing the Webtool to be hoisted into position to cut the steelwork in different orientations.

Remote blade and anvil replacement

For another decommissioning project where the levels of radiation precluded human intervention, the guillotine blade had to be replaceable using remote manipulation. In this case, a cradle was fabricated allowing the blade and anvil to be removed by manipulating two quick release toggles and tilting the tool.

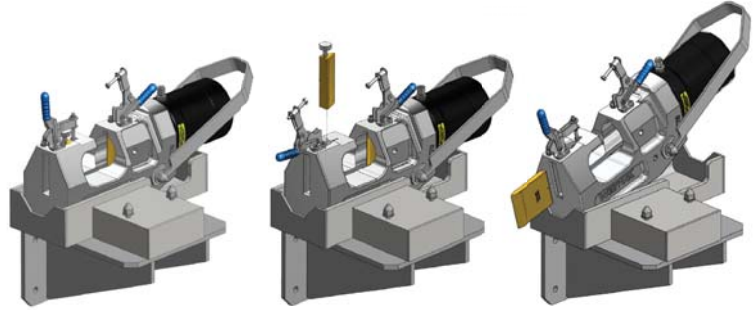

Tool Selection



Webtool croppers for nuclear decommissioning and maintenance are available in a range of standard sizes. We are able to assist with tool selection, including: blade material and geometry, cutting technique and power requirements.

Multi-position handling frame

Webtool is able to assist with the supply of project-specific handling frames. For the Sellafield project a multi-position lifting frame was provided that allowed the cutter to be hoisted into position to cut the steelwork in different orientations.





Webtool provides a full design and project management service including tool and blade selection from a range of standard cutting tools, and handling frames, together with comprehensive test facilities.

Allspeeds is the sole manufacturer of Webtool hydraulic cutters and systems, Tangye lifting jacks and hydrostatic test pumps, Millingford sucker rod pumps, Kopp variable speed drives and Blake Hydram water pumps.



The cutting edge of decommissioning

Webtool guillotine croppers are a powerful addition to the engineer's toolbox. They are simple but effective croppers and suitable for a wide range of cropping tasks. Importantly they are a real alternative to traditional cutting methods where swarf, dust and high levels of radiation are an issue.

To find out more about Webtool nuclear decommissioning and maintenance tools, call **+44 (0)1254 615 100** or email **info@allspeeds.co.uk**

Allspeeds Ltd

Royal Works, Atlas Street
Clayton-Le-Moors
Accrington
Lancashire
BB5 5LW

Tel: **+44 (0)1254 615 100**
Email: **info@allspeeds.co.uk**
Web site: **www.allspeeds.co.uk**

