



Allspeeds Ltd.  
Royal Works, Atlas St  
Clayton le Moors  
Accrington  
Lancashire  
England  
BB5 5LW

Tel +44 (0)1254 615100

[www.allspeeds.co.uk](http://www.allspeeds.co.uk)

**WIRE ROPE CUTTER WCO30DLP**

**PRODUCT No. 980526**

**INSTRUCTIONS FOR INSTALLATION,  
OPERATION & MAINTENANCE**

Mod No - 20769 Date 2<sup>nd</sup> Oct 2014  
© Copyright Allspeeds Holdings Ltd.

**This document must not be modified in any way.**

## Table of Contents

<b>1</b>	<b>Introduction.....</b>	<b>3</b>
<b>1.1</b>	<b>Technical Data .....</b>	<b>3</b>
<b>1.2</b>	<b>Environmental Considerations.....</b>	<b>3</b>
<b>1.3</b>	<b>Cutter Dimensions.....</b>	<b>4</b>
<b>1.4</b>	<b>Declaration of Incorporation .....</b>	<b>5</b>
<b>2</b>	<b>General Safety Rules .....</b>	<b>6</b>
<b>2.2</b>	<b>Warning Labels .....</b>	<b>7</b>
<b>3</b>	<b>Operating Instructions.....</b>	<b>8</b>
<b>3.1</b>	<b>Machine Description .....</b>	<b>8</b>
<b>3.2</b>	<b>Before Use .....</b>	<b>8</b>
<b>3.3</b>	<b>Operational Procedures.....</b>	<b>9</b>
<b>3.4</b>	<b>After Use .....</b>	<b>12</b>
<b>4</b>	<b>Maintenance.....</b>	<b>13</b>
<b>4.1</b>	<b>Maintenance Notes .....</b>	<b>13</b>
<b>4.2</b>	<b>Replacing Parts .....</b>	<b>13</b>
<b>4.3</b>	<b>Anvil Replacement .....</b>	<b>14</b>
<b>4.4</b>	<b>Blade Replacement .....</b>	<b>15</b>
<b>4.5</b>	<b>Main Cylinder Replacement.....</b>	<b>16</b>
<b>4.6</b>	<b>Troubleshooting .....</b>	<b>19</b>
<b>5</b>	<b>Transportation .....</b>	<b>19</b>
<b>5.1</b>	<b>Transportation Method .....</b>	<b>19</b>
<b>5.2</b>	<b>Cutter Handling.....</b>	<b>19</b>
<b>6</b>	<b>Installation &amp; Commissioning .....</b>	<b>20</b>
<b>6.1</b>	<b>Installation.....</b>	<b>20</b>
<b>6.2</b>	<b>Equipment Assembly.....</b>	<b>20</b>
<b>6.3</b>	<b>Hydraulic Connections &amp; Mounting Points .....</b>	<b>21</b>
<b>7</b>	<b>Commissioning.....</b>	<b>23</b>
<b>7.1</b>	<b>Blade Inspection.....</b>	<b>23</b>
<b>7.2</b>	<b>Anvil Inspection .....</b>	<b>23</b>
<b>7.3</b>	<b>Function Testing.....</b>	<b>23</b>
<b>8</b>	<b>Decommissioning .....</b>	<b>24</b>
<b>9</b>	<b>Parts List Identifier .....</b>	<b>25</b>
<b>9.1</b>	<b>Parts List Identifier 9.2 Parts list .....</b>	<b>25</b>
<b>10</b>	<b>Optional Extras .....</b>	<b>28</b>

## 1 Introduction

The WCO30DLP is a double acting tool primarily intended for use on steel wire rope up to  $\varnothing$  28mm, having a maximum tensile strength of 2160N/mm.

For information regarding the cutting capacity on alternative items or materials, please contact the manufacturer (Allspeeds Ltd) before proceeding.

This equipment is not intended for use in an explosive environment.

### 1.1 Technical Data

#### **WCO30DLP Cutter (980526)**

Weight of WCO30DLP in air	19.808kg ( <i>no oil</i> )
Weight of WCO30DLP in water	17.245kg ( <i>no oil</i> )
WCO30DLP dimensions	341mm x 157mm x 134.5mm
Hydraulic requirements - Blade	210 Bar (3046 psi)

### 1.2 Environmental Considerations

The cutter must not be operated outside of the recommended temperature range of -5°C to 60°C. This tool can be operated in areas of radiation but a full risk assessment must be carried out on site before use. Ensure connections and fittings are water tight before entering a marine environment.

**1.3 Cutter Dimensions**

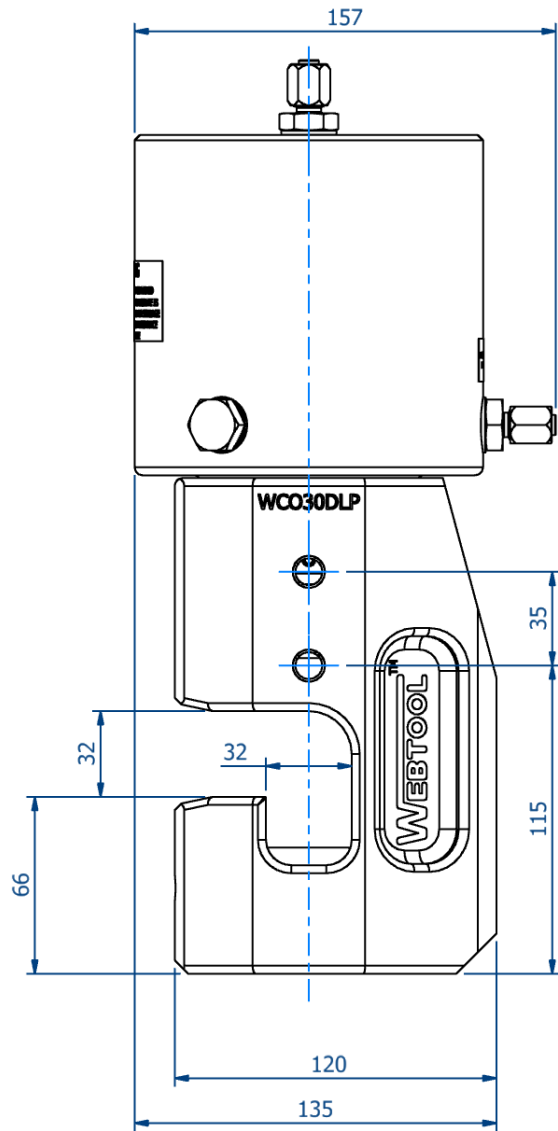
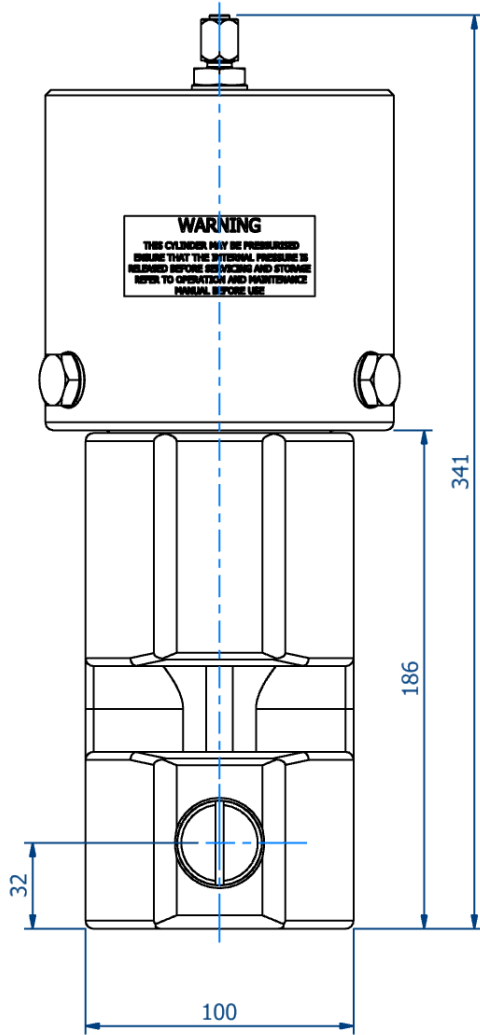
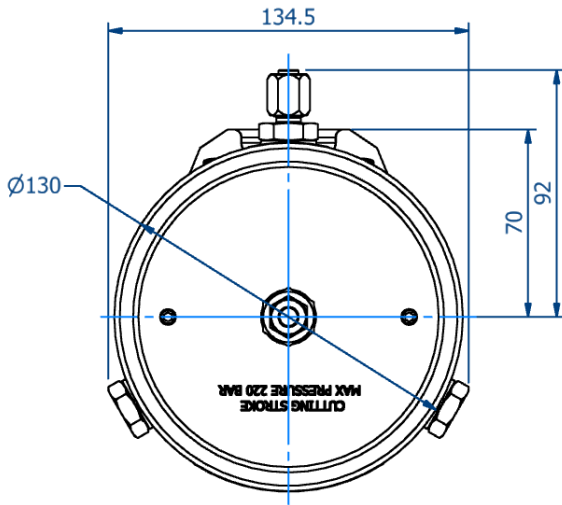

## 1.4 Declaration of Incorporation

See Insert

## 2 General Safety Rules

### 2.1.1 Warnings

These warnings are provided to improve safety and should be carefully read before installing, using or maintaining the equipment.

### 2.1.2 Important Information

It is vital that these instructions are available to the equipment users. It is also important they are retained with the equipment if it is sold or transferred to another user.

### 2.1.3 Safety for Operation

To prevent the risk of injury, the WCO30DLP should only be used by fully trained and competent operators.

**Note – It is the responsibility of the operator to perform a risk assessment before use and to enforce a safe system of work.**

- Make sure all safety devices are in place and functioning correctly.
- Make sure the working area is free of any obstructions.
- Check that all hydraulic hoses are in good condition.
- Ensure that all operators are clear of the area before cutting commences.
- No attempt should be made to cut any materials that are under tension.

Recommended PPE for operation and maintenance includes safety shoes, safety glasses, ear defenders and gloves.



**IMPORTANT** – Any spilt oil or trailing hoses may create a slipping or tripping hazard. Care must be taken around the work area. Energised hoses may move about during operation, ensure all operators are clear and that hoses are routed so that no damage to the hoses can occur.

### 2.1.4 Safety for Maintenance

Repairs carried out by untrained or unauthorised personnel may result in personal injury or serious malfunction of the tool.

Ensure that the cutter is isolated from and drained of hydraulic pressure before any maintenance is carried out.

## 2.2 Warning Labels

	<p>General hazard. Hydraulic cutting tool with inherently dangerous moving parts. Please read and understand this manual to avoid the risk of injury.</p>
	<p>Cut or severing hazard due to the cutting blade.</p>

### 3 Operating Instructions

#### 3.1 Machine Description

The tool assembly consists of the following components:

- WCO30DLP Cutter

#### 3.2 Before Use

Before use of the tool, perform the following checks:

Item	Procedure
Check the condition of the anvil	As described in section 4.3
Check the condition of the blade	As described in section 4.4



### 3.3 Operational Procedures

IMPORTANT – Ensure that the blade and anvil are in suitable condition before use as described in section 4.3/4.4 and that the tool has been function tested (as described in section 7.3)

#### 3.3.1 Retract the Blade

Retract the blade by energising the “Main Ram Retract Port”. Ensure that the “Main Ram Power Port” is open to tank.

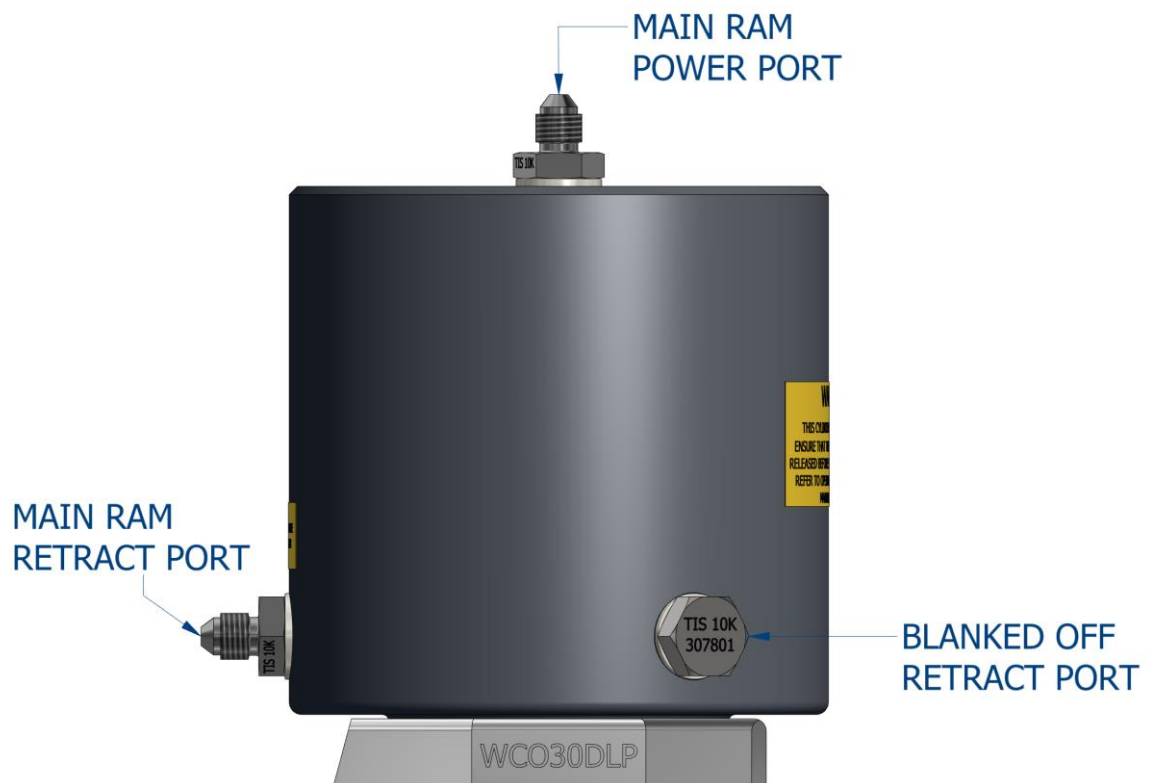

### 3.3.2 Position the Cutter

**IMPORTANT** - Ensure that the cutter assembly is lifted as described in section 5.2

Before deployment, function test the tool and ensure that all operators are familiar with this procedure. ROV observation of the tool should be maintained at all time during operation.

Prior to use, ensure no excessive damage has occurred to the blade or anvil. Check the blade edge for cracks and chips.

Place the wire rope in the cutter. Ensure that the wire rope is as far into the cutter as possible.

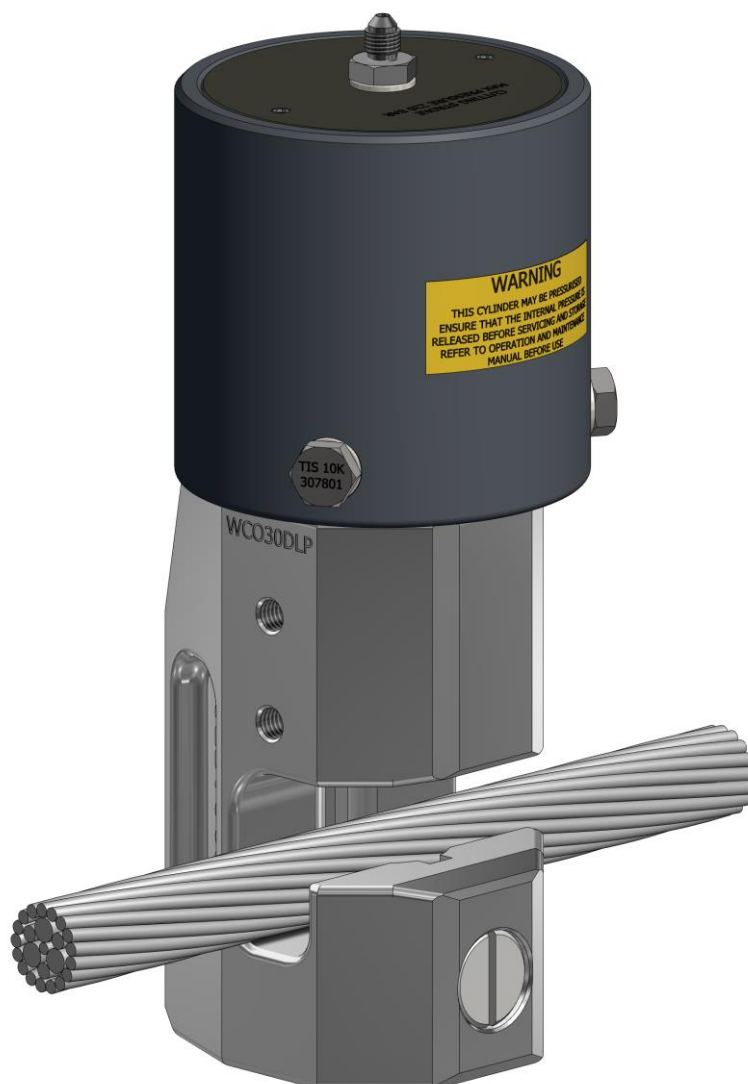

### 3.3.3 Cutting

To perform a cut pressurise the “Blade Down/Cut Cylinder Down” line in to the “Main Ram Power Port”. Ensure that the “Main Ram Retract Port” is open to tank. The blade will begin to move towards the item to be cut.

As the blade begins to cut, the pressure in the “Blade Down/Cut Cylinder Down” line will begin to increase.

Once the hose is severed, pressurize the “Main Ram Retract Port” to withdraw the cutting blade. Ensure that the “Main Ram Power Port” is open to tank.

**IMPORTANT** – The item being cut may be ejected from the tool with force. Ensure that operators are kept at a safe distance at all times.

**IMPORTANT** - A loud noise may be emitted as the item is cut, ensure that suitable ear defenders are worn at all times. A risk assessment must be carried out by the operator before cutting.

### 3.3.4 After Cutting – Retract the Blade

Pressurise the “Blade Up/Cut Cylinder Up” line to the “Main Ram Retract Port” to retract the blade. Ensure that the “Main Ram Power Port” is open to tank. Release the pressure once the blade is fully retracted.

### 3.3.5 Guards

**IMPORTANT** - There are no guards fitted to the WCO30DLP.

The WCO30DLP is an inherently dangerous cutting tool and at no times should personnel or operators place any part of the body within the cutting area or any other snag or trap points.

Misuse of this tool can result in serious injury or death.

### 3.4 After Use

**IMPORTANT:** Do not store the tool with a completely sealed cylinder as pressure may build up due to environmental temperature changes.

When the tool is retrieved from a marine environment, it should be hosed off with clean water, allowed to drain and sprayed externally with a de-watering fluid.

If this cutter has been exposed to radiation it must be stored in accordance with current local regulations.

The blade edge should also be smooth and free from any excessive damage/serrations.

Note that a slight ripple to the blade edge is acceptable and will not cause problems. Any minor damage can be smoothed off with an oil stone if necessary.

## 4 Maintenance

It is unlikely that service would be required on the hydraulic components of the tool under normal circumstances, but a seal spares kit is available and it is recommended to keep stock at all times(995151). The only parts that would need intermittent replacement would be the anvil and blade, depending on the frequency of use, materials being cut and the corrosive conditions present during operation.

### 4.1 Maintenance Notes

**IMPORTANT** – The WCO30DLP should only be serviced by qualified personnel. If in any doubt please contact Allspeeds Ltd.

Most maintenance task can be carried out with standard tools.

All servicing operations should be carried out in a clean environment to prevent contamination of the oil and mating components.

Care should be taken with all mating areas, including threads and sealing faces, as any damage or abrasive contamination could cause galling or seizing on re-assembly. Please note a suitable anti-galling paste should be used (we recommend Swagelok Silver Goop) on all stainless steel threads.

The cylinder and cutter body are pressure vessels and should not be drilled, machined, mutilated or damaged in any way for mounting purposes or to assist in its removal for servicing, any warranty could be invalidated by such actions (see section 4.5).

The use of a Stilson wrench to remove the cylinder is not recommended as damage will occur.

When removing the cylinder, the hydraulic fittings should first be removed. Screw a ¼” BSP threaded bar into each of the opposing ports. Apply a torque and not a bending moment when screwing and unscrewing the cylinder (see section 4.5).

Before carrying out any maintenance tasks ensure that the equipment is fully isolated and that there is no residual pressure in the system.

### 4.2 Replacing Parts

See parts list identifier for details of component parts (see section 4.5.1, 4.5.2 and 9)

**IMPORTANT** - Replacement parts must always be sourced from Allspeeds Ltd. The use of unofficial components will invalidate the warranty and may lead to tool damage or system failure.

It is recommended that stock of the components listed below is kept at all times:

Seal Kit	Part Number	995121
Anvil	Part Number	761278
Blade	Part Number	705032C
Blade Retaining Pin	Part Number	030522

### 4.3 Anvil Replacement

Release the cap headed screw in the back of the cutter, this will allow the anvil (761278) to be easily removed from the cutter. If the anvil surface is badly marked it can be rotated to offer up a new surface when further cuts are to be made. Once all clean faces have been used and the anvil becomes difficult to remove the anvil needs replacing.

Re-assembly is the reverse of the above process.

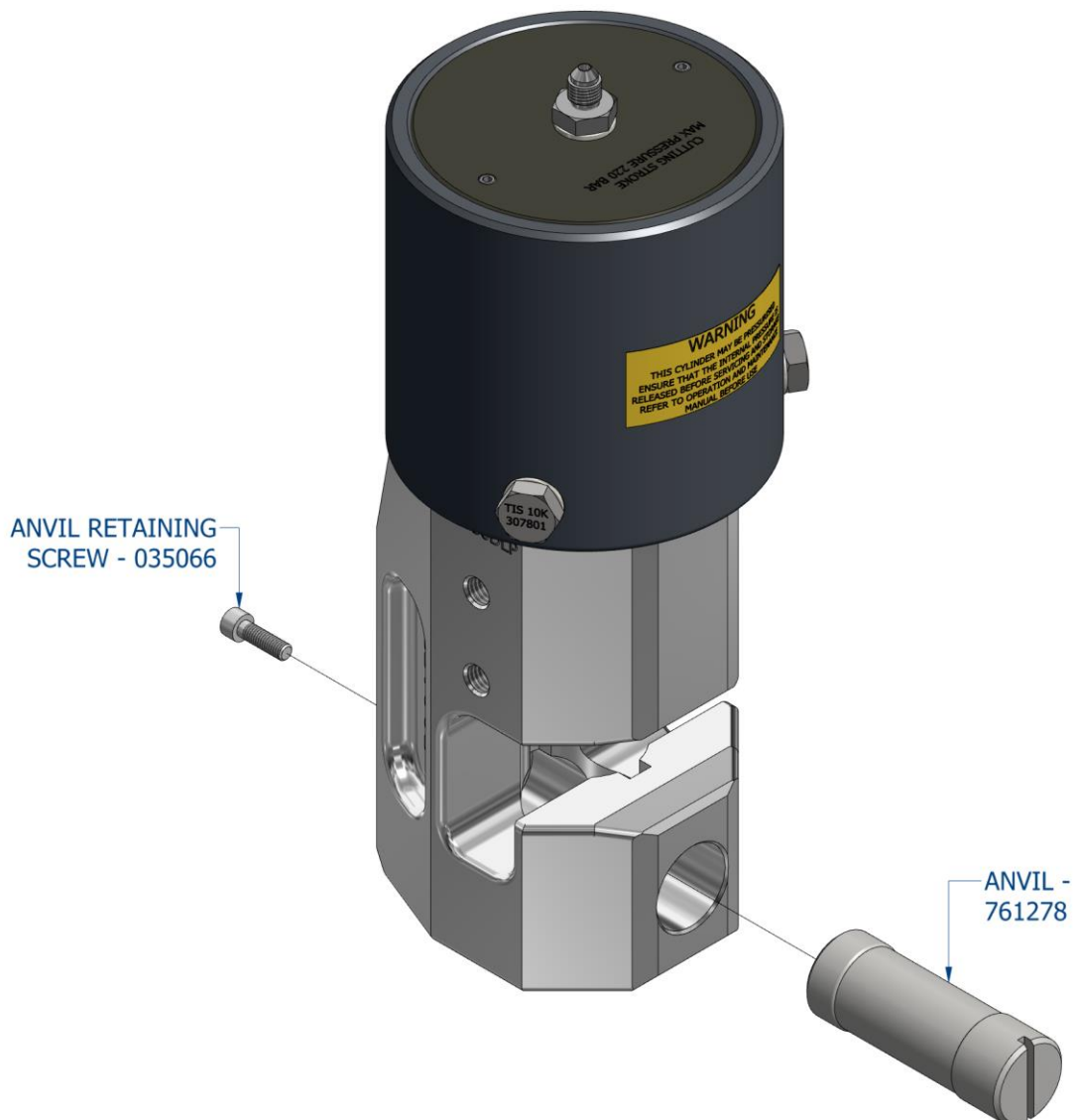

## 4.4 Blade Replacement

First withdraw the anvil as previously described in section 4.3.

Pump out the main ram until the blade retaining pin (030522) can be seen in the hole in the cutter body. Remove the pin (030522) with a drift and slide the blade (705032C) out of the tool.

Gloves must be worn to protect the hands when removing the blade from the tool.

When fitting the new blade ensure the retaining pin is within the outer diameter of the ram on both sides.



## 4.5 Main Cylinder Replacement

The use of a Stilson wrench to remove the cylinder is not recommended as damage will occur.

The cylinder is a pressure vessel and should not be drilled, machined, mutilated or damaged in any way for mounting purposes or to assist in its removal for servicing, any warranty could be invalidated by such actions.

If it is necessary to replace the hydraulic seals, first remove the blade as described previously in section 4.4, ensuring no residual pressure remains in the system. The cylinder must then be removed from the tool. The hydraulic ports used by the hydraulic connectors (791157) and blanking plug (766100) on the sides must be used to unscrew the cylinder using the cylinder removal tool kit (999035 – not supplied).

The hydraulic fittings should first be removed (ensure the cylinder is free from pressure and drained of oil), then fit the cylinder assembly ring (778018) with the ¼" BSP Location Screws (035170). Ensure that the ¼" BSP screws tighten and bottom out on the cylinder port faces. Once the ring is secured to the cylinder, screw in the M12 handles (748072) and turn. This method should be used to ensure a torque and not a bending moment is applied when screwing the cylinder into and out of the body.

Do not use stilsons to remove the cylinder as damage will occur.

Please see overleaf for an exploded view of the main components within the cylinder assembly.

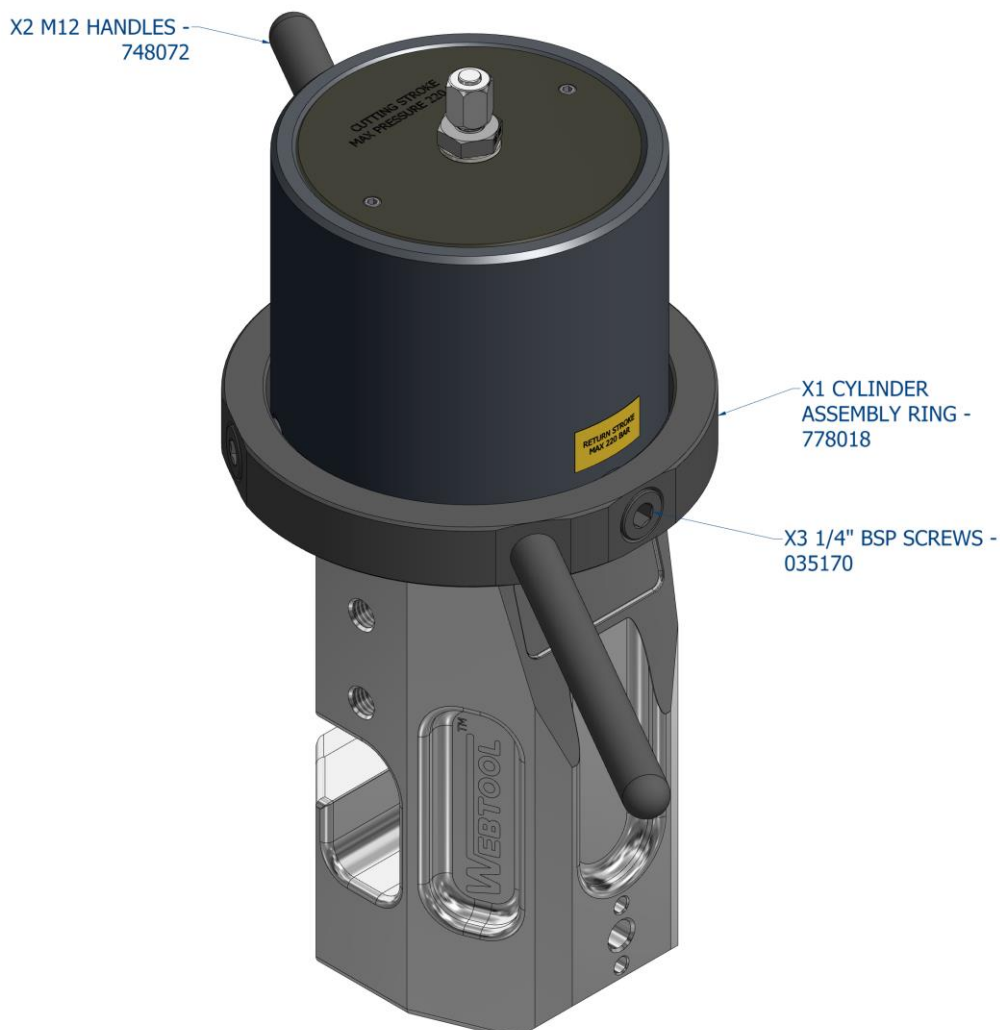



### 4.5.1 Exploded View of Internal Components

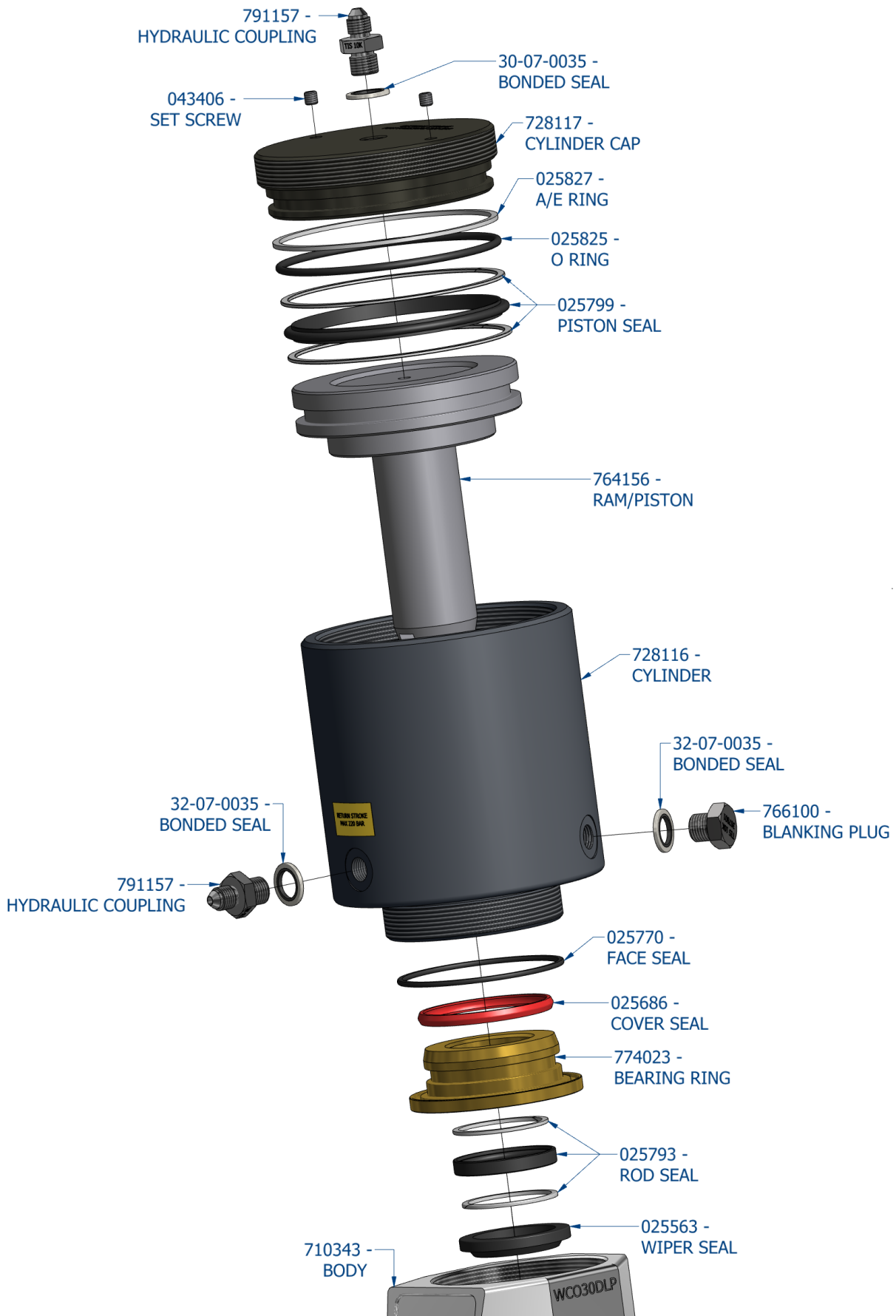

4.5.2

View of Internal Components in Assembled State

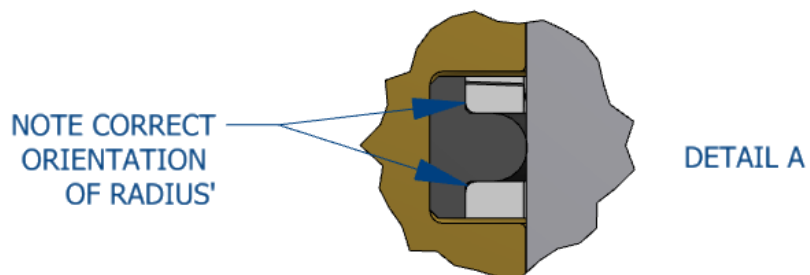
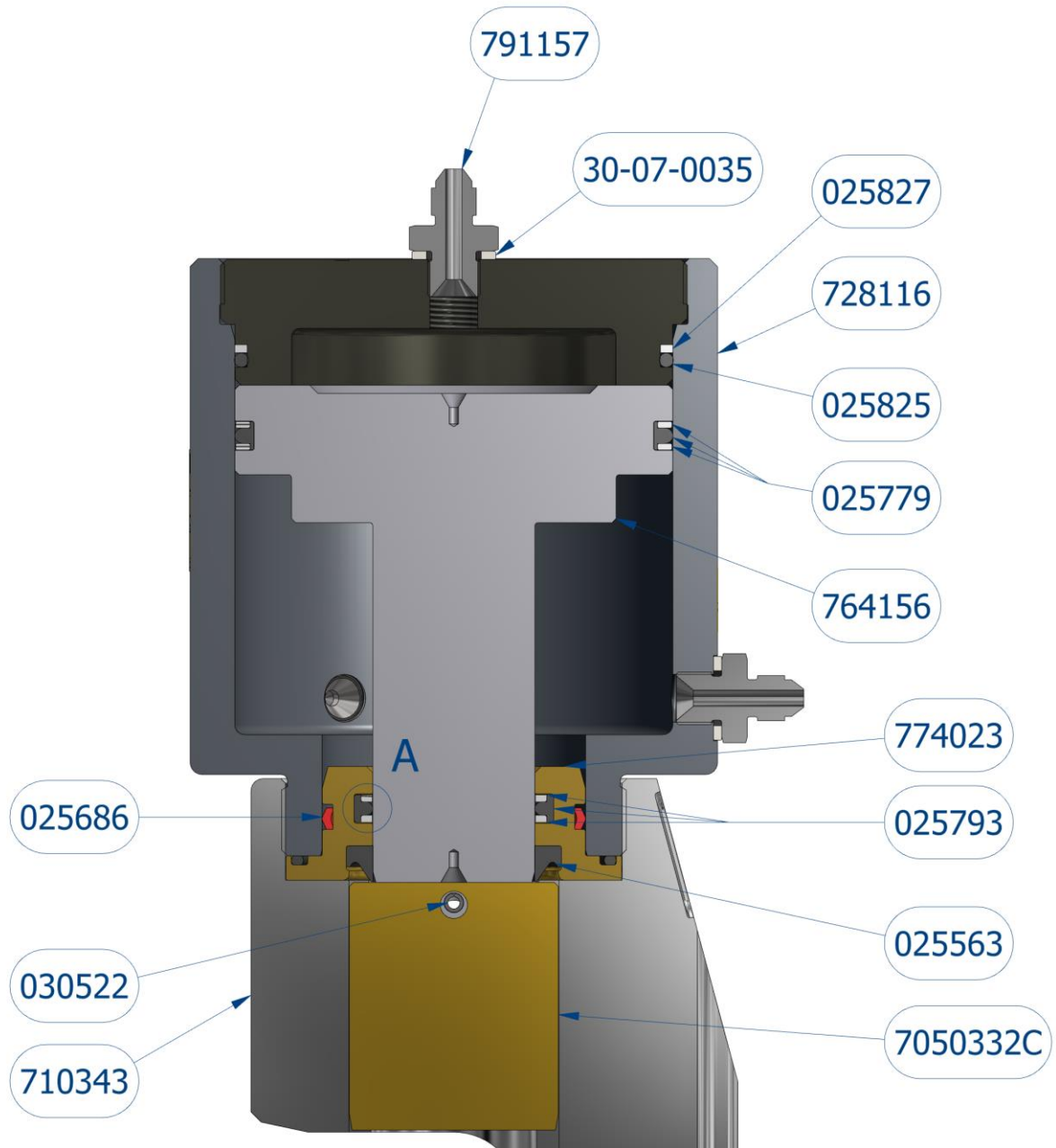

## 4.6 Troubleshooting

### 4.6.1 Common Problems

Blade will not move down;

- The “Blade Down/Cut Cylinder Down” line must be pressurised before cutting can commence. The “Main Ram Retract Port” must be open to tank.
- Ensure the hydraulic supply has sufficient tank volume to fully drain the “Main Ram Retract Port” line.

The wire rope does not cut through completely on the first attempt;

- Cycle the blade by retracting it slightly and then attempting the cut again.

The wire rope is still not severed after multiple cycles at a pressure of 210 Bar;

- Retract the blade, isolate the hydraulic supply and inspect the blade and anvil. Replace if necessary.

## 5 Transportation

This chapter explains how to move and install the equipment.

### 5.1 Transportation Method

The weight of the WCO30DLP without oil is 19.812 kg. This tool is above maximum weight as stated by the Manual Handling Directive to be moved by hand. Do not attempt to move this tool by hand.

Attempting to move this tool by hand may result in personal injury. Use mechanical aids to move this tool as described in section 5.2.

### 5.2 Cutter Handling

The WCO30DLP has pre machined M12x1.75 – 6H holes in the body. These can be used to locate certified eyebolts for crane lifting.

## 6 Installation & Commissioning

### 6.1 Installation

**IMPORTANT** - Hydraulic connections should only be made by qualified and competent personnel.

Four tapped holes, M12 x 25 deep, are provided in the tool body which can be used for any attachment necessary to mount the cutter. The cylinder is a pressure vessel and is not recommended as a mounting point, the cylinder should not be drilled, machined, mutilated or damaged in any way, any warranty could be invalidated by such actions.

A hydraulic supply is required, ported as shown in section 6.3. The maximum working pressures are shown in table 1 on page 22. Pressure limiting valves must be fitted into the supply to limit the pressures to these levels.

A relief valve should also be incorporated in the return line. This is to prevent excessively high pressures in the annular side of the hydraulic cylinders should the return to tank become blocked for any reason.

The oil supply must be clear and free from contamination. A good quality ISO32 grade hydraulic oil, e.g. Shell Tellus 32 or equivalent, is suitable.

The weight of the tool is 19.812kg.

Before deployment, function test the tool and ensure that all operators are familiar with this procedure. ROV observation of the tool should be maintained at all time during operation.

Prior to use, ensure no damage has occurred to the blade or anvil.

### 6.2 Equipment Assembly

The WCO30DLP is supplied in a pre-assembled state.

### 6.3 Hydraulic Connections & Mounting Points

A hydraulic supply is required, ported as shown. The maximum working pressures are shown in Table 1 overleaf. Pressure limiting valves must be fitted into the supply to limit the pressures to these levels.



**Table 1 – Working Pressure & Swept Volume**

Function	Working Pressure		Swept Volume	
	psi	Bar	ml.	U.S. Gallon
Working Stroke	3,000	210	500	(0.088)
Return Stroke	3,000	210	420	(0.050)

*Please note: Max working pressure and max return stroke pressure is 210 Bar.*

**IMPORTANT – Do not exceed the pressures stated. Doing so may lead to damage to the tool or injury to operators.**

**IMPORTANT – Care must be taken when making or breaking connections to avoid oil spills as they may result in a slipping hazard.**

**Contact with hydraulic oil may result in skin irritation. Ensure that suitable protective equipment is used and/or worn.**

## 7 Commissioning

The WCO30DLP is supplied fully assembled and will contain residual oil from testing. The system may need topping up with oil and bleeding before cutting operations can commence smoothly. This can be performed by cycling the blade up and down several times at low pressure. Ensure relevant ports are open to tank during cycling.

Before putting the machine into service, the following checks must be carried out:

**CAUTION – USE OF BLADES AND PARTS NOT SUPPLIED OR APPROVED BY WEBTOOL MAY RESULT IN TOOL FAILURE AND CONSEQUENTIAL DAMAGE**

### 7.1 Blade Inspection

With the cutter isolated from the hydraulic supply, check the condition of the blade edge. Ensure that care is taken when checking the blade as the edge may be sharp or have a build-up of cold weld on the surface. Protective gloves should be worn.

If the blade is damaged replace with a fresh blade before cutting. Replacement is as described in section 4.4.

### 7.2 Anvil Inspection

Check the condition of the anvil.

It is normal that the anvil will show an indent where the blade has pressed down into it. It is designed to withstand multiple cuts, but any excessively damaged anvil should be replaced. Replacement is as described in section 4.3.

### 7.3 Function Testing

Retract the blade by pressurising the “Cut Cylinder Up/Blade Up” line in to the “Main Ram Retract Port”. Check that it moves freely. Ensure that “Main Ram Power Port” is open to tank

## 8 Decommissioning

Major components are made from the following recyclable materials:

<b>Part Number</b>	<b>Description</b>	<b>Material</b>
728116	Cylinder	Alloy Steel
710343	Cutter Body	Stainless Steel
764156	Ram	Stainless Steel
761278	Anvil	Stainless Steel
705032C	Blade	Stainless Steel

Remaining components should be disposed of in accordance with local current regulations. Hydraulic fluid should be drained into a suitable container and disposed of in accordance with current local regulations.



**9 Parts List Identifier**

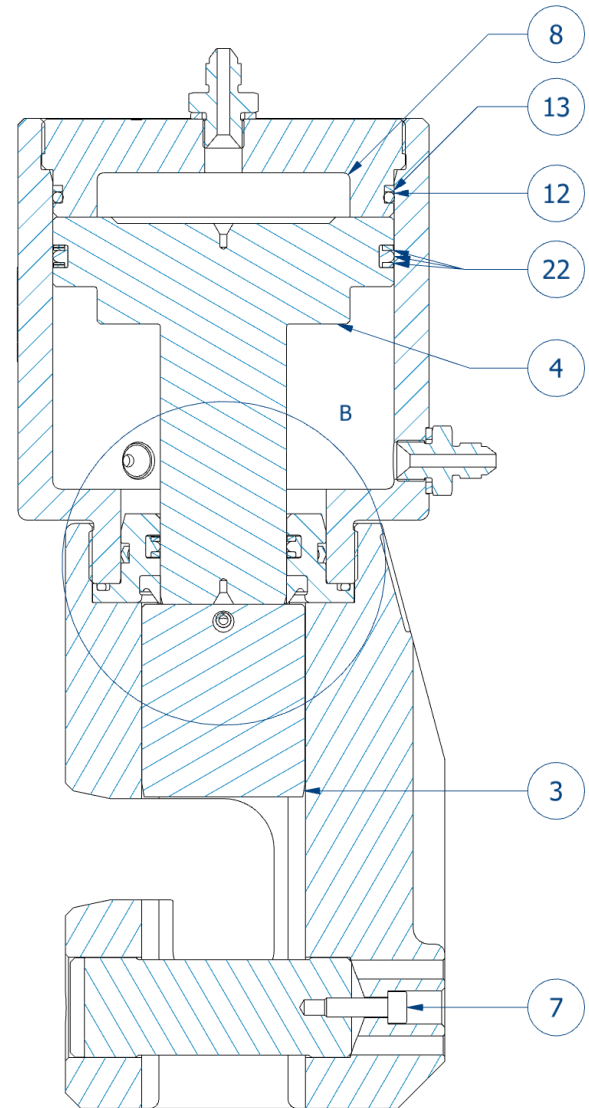
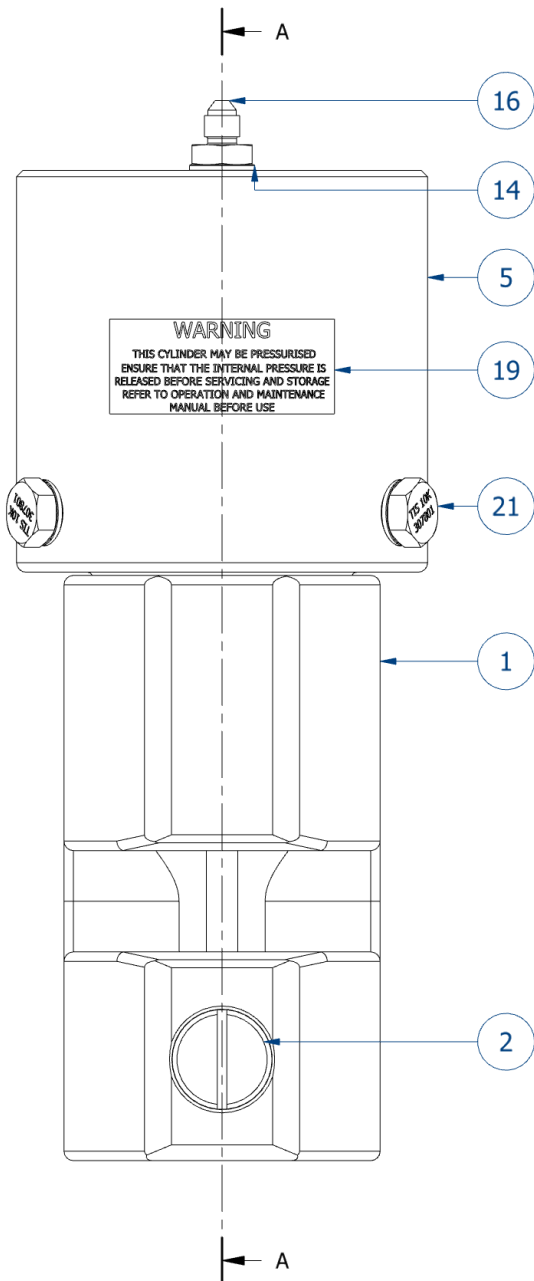
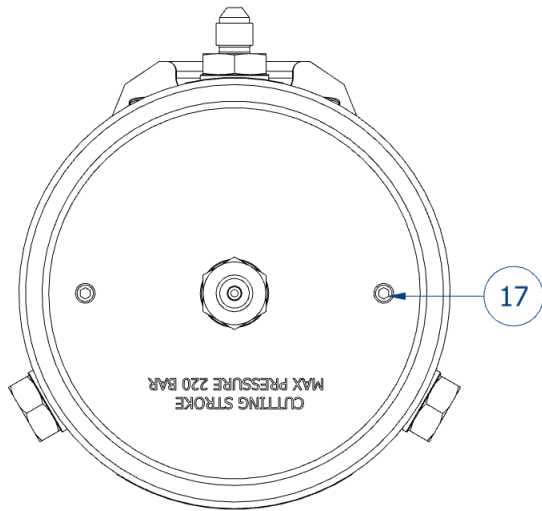

SECTION A-A

## 9.1 Parts List Identifier

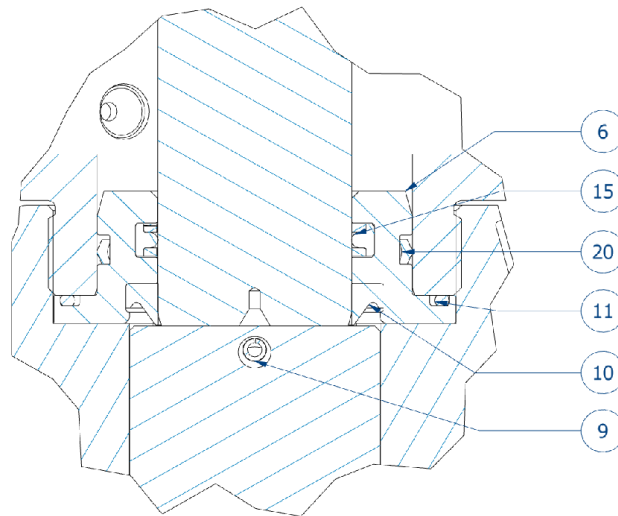

DETAIL - B

DETAIL OF  
INTERNAL COMPONENTS

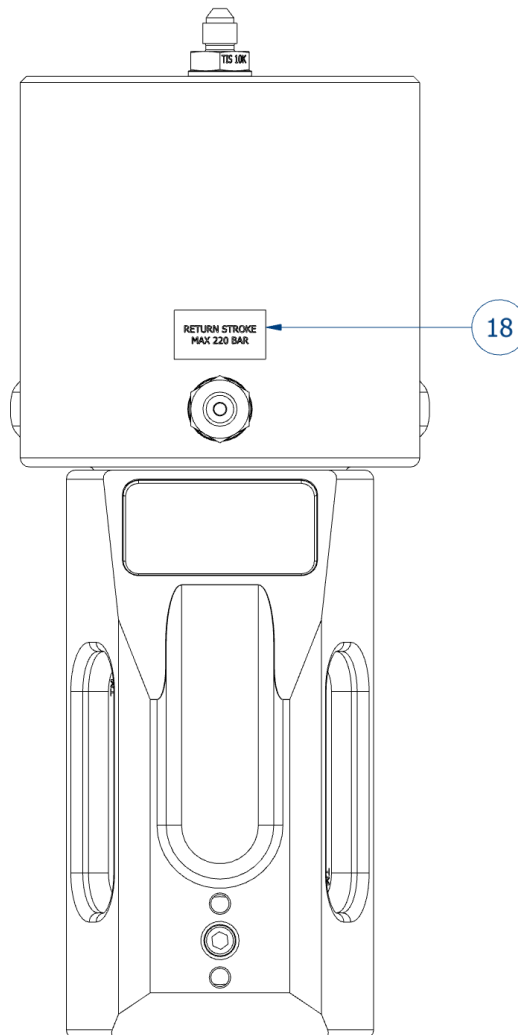

## 9.2 Parts list

PARTS LIST			
ITEM	QTY	PART NUMBER	DESCRIPTION
1	1	710343	CUTTER BODY
2	1	761278	ANVIL
3	1	705032C	BLADE
4	1	764156	RAM/PISTON
5	1	728116	LOW PRESURE CYLINDER
6	1	774023	BEARING RING
7	1	035066	ANVIL SCREW
8	1	728117	CYLINDER CAP
9	1	030522	STAINLESS SPRING PIN
10	1	025563	# WIPER SEAL
11	1	025770	# O' RING BEARING RING/CYLINDER
12	1	025825	O RING CYLINDER CAP
13	1	025827	# A/E RING
14	4	32-07-0035	# BONDED SEAL 1/4" BSP
15	1	025793	# ROD SEAL
16	2	791157	1/4" BSPP TO JIC 4 STRAIGHT ADAPTOR
17	2	043406	SOCKET SET SCREW
18	1	752572 R65	PORT PRESSURE LABEL
19	1	752573 R65	PRESSURE WARNING LABEL
20	1	025686	# KB26 COVER SEAL
21	2	766100	1/4" BSPP BLANKING PLUG
22	1	025799	# PISTON SEAL

# = SEAL KIT ITEMS (995121)

## 10 Optional Extras

**Webtool handle kit** – Part number 999023 is available for this cutter and is shown below.

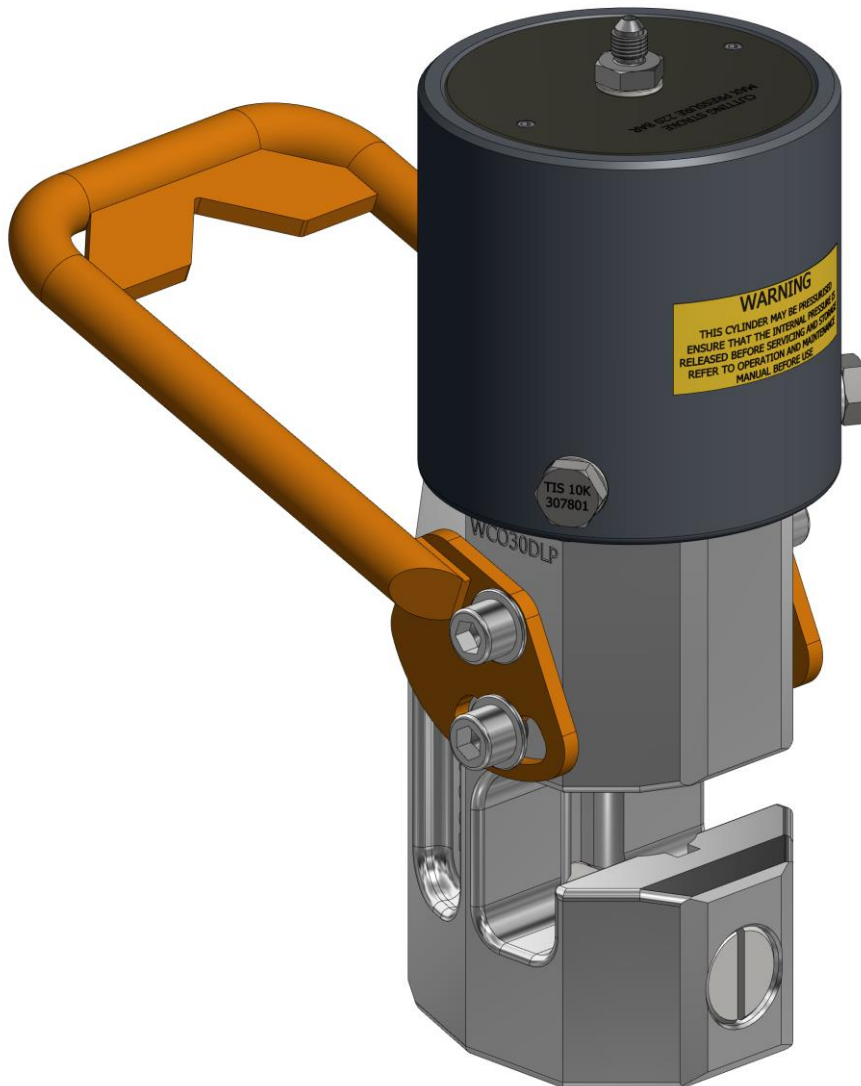

# WEBTOOL<sup>TM</sup>

## CUTTING EDGE TECHNOLOGY

Webtool specialises in engineering powerful hydraulic tools for cutting and gripping rope, cable and umbilicals.

Models designed for use in subsea environments by ROV's, and surface applications in hostile environments.

- Wire rope cutters (WCS and WCOS) – capable of cutting steel wire rope up to 75mm diameter
- Wire Rope Cutters (RCV) – capable of cutting steel wire rope up to 190mm diameter
- Cable Cutters (HCV) – capable of cutting cable, umbilical and armoured flexible pipe lines up to 330mm diameter
- Softline Cutters (SL) – capable of cutting fibre ropes in various sizes
  - Wire Rope / Cable Grippers
    - Wire Rope Clamps
    - Automatic Shackles

### Application specific solutions

Our in house design and manufacturing capability means we can quickly and efficiently develop a solution to suit your particular application.

Contact our engineering department to discuss how we can help.

Allspeeds Ltd, Royal Works, Atlas Street, Clayton-Le-Moors,  
Accrington, Lancashire, BB5 5LW, England

T: +44 (0)1254 615100

F: +44 (0)1254 615199

E: [info@allspeeds.co.uk](mailto:info@allspeeds.co.uk)

W: [www.allspeeds.co.uk](http://www.allspeeds.co.uk)