



Allspeeds Ltd.
Royal Works, Atlas St
Clayton le Moors
Accrington
Lancashire
England
BB5 5LW

Tel +44 (0)1254 615100
www.allspeeds.co.uk

RCO54 WIRE ROPE CUTTER

PRODUCT CODE No. 980495

**INSTRUCTIONS FOR INSTALLATION,
OPERATION & MAINTENANCE**

Revision 1 issue 2. Modification No. 20617 Date 02/05/2014

© Copyright Allspeeds Holdings Ltd.
This document must not be modified in any way.

Description

The RCO54 is a double acting tool primarily intended for use on steel wire rope, having a maximum tensile strength of 1960N/mm, up to 54mm diameter. It may be used on alternative materials, such as electrical power or communication cables, again up to a maximum of 54mm diameter.

1. **SAFETY**

Before operation, read and understand this operations manual. Whilst the tool is intended for remote or local operation subsea, there is no reason why it should not be used above surface.

Ensure that the tool, hoses and pump are in good condition and properly connected. Ensure that suitable pressure regulation equipment is used and that the unit is not subjected to pressures higher than those stated in section 3, table 1.

In all cases, where an operator is present, the safety aspects must be reviewed before the cutting operation is commenced.

No attempt should be made to cut wire ropes or other material that is under tension.

Ensure that the operator is shielded from the cutting blade during the cutting operation.

When cutting near the very end of hose or rope, individual cut wires can be expelled from the tool, please ensure that the operator is shielded from these. If in doubt please contact the manufacturer (Allspeeds Ltd) or an authorised distributor for assistance.

The maximum proof test pressure should not exceed 125% of the maximum working pressure and this should only be done by Allspeeds using our specially adapted test rig. The tool should be guarded during the proof test operation, and be carried out in a safe working environment. The proof pressure should be applied gradually, until the maximum pressure is reached.

Important: Please note this tool is designed for intermittent subsea use. Please refer to the manufacturer (Allspeeds Ltd) or an authorised distributor should you wish to use this tool subsea for any period over 14 days.

CAUTION - Any modification made to this tool will invalidate the warranty and may lead to equipment failure or personal injury. If in doubt please contact the manufacturer (Allspeeds Ltd) or an authorised distributor for assistance.

INSPECT THE TOOL BEFORE USE

With the cutter isolated from the hydraulic supply, check the condition of the blade edge. If the blade is damaged replace with a fresh blade before cutting. This procedure is as described in section 8.

Ensure that care is taken when checking the blade as the edge may be sharp.

Check the condition of the anvil. It is normal that the anvil will show an indent where the blade has pressed down into it and can withstand multiple cuts, but any excessively damaged anvil should be replaced.

CAUTION – USE OF BLADES AND PARTS NOT APPROVED BY WEBTOOL MAY RESULT IN TOOL FAILURE AND CONSEQUENTIAL DAMAGE

2. CUTTING CAPACITY

The cutting range begins at 32mm diameter wire rope with a maximum tensile strength of 2160N/mm up to 51mm diameter with maximum tensile strength of 1960N/mm. The tool may be used on alternative materials, such as electrical power or communication cables, again up to a maximum of 51mm diameter. Where smaller diameters are to be cut, effort should be made to place the material centrally along the anvil to minimise any offset loading. This cutter is not intended for use on chain or solid steel bar.

IMPORTANT: Please note this tool is capable of cutting wire rope with a minimum strand diameter of 1.2mm. We recommend that cutting is performed at a distance no less than 10X rope diameter from the end, otherwise premature blade failure may occur.

The table below represents both the guaranteed capacity and known application data for Webtool steel wire rope cutters. Where tools are known to be capable of cutting larger or tougher ropes these are also indicated, but the manufacturer can only guarantee the cutting capacity stated in the operating manual. If you need information on superceded or obsolete models please contact us.

Please check our website regularly for new products. Note: For compacted ropes (i.e.Dyform) assume rope is one grade higher than actual.

Model	Part No.	Wire rope size, and corresponding rope grade (N/mm ²)													
		1/2"	3/4"	1"	1.25"	1.5"	1.75"	2"	2.5"	3"	4"	4.5"	5"	6"	7.5"
		13mm	19mm	25mm	32mm	38mm	45mm	51mm	64mm	76mm	102mm	115mm	127mm	153mm	190mm
WCS22D	980468	1960	1770												
WCOS22D	980493	1960	1770												
WCS38D	980487	2160	2160	2060	1960	1770									
WCOS38D (Obsolete)	980490	2160	2160	2060	1960	1770									
WCOS38DLP (Obsolete)	980488	2160	2160	2060	1960	1770									
RCO40	980502			2160	2060	1960									
RCO40LP	980503			2160	2060	1960									
WCS54D	980492				2160	1960	1960	1770							
WCOS54D	980485				2160	1960	1960	1770							
RCO54	980495				2160	2160	1960	1960							
WCS75D (Obsolete)	980480					1960	1770	1770	1770						
WCS75HD	980483					2160	2060	1960	1770	1770					
WCS75HDZ	980482					2160	2060	1960	1770	1770					
RCV75	980296					2160	2160	1960	1770	1770					
RCV75HD	980235					2160	2160	2160	2160	1960					
RCV115	980290					2160	2160	2160	2160	2160	1960	1770			
RCV135	980212							2160	2160	2160	1960	1770	1770		
RCV155	980218									2160	2160	2160	1960	1880	
RCV190	980230									2160	2160	2160	2160	1960	1880

3. INSTALLATION

Four tapped holes, M12 x 20 deep, are provided in the tool body (see below) which can be used for any attachment necessary to mount the cutter, such as the Webtool handle assembly (999024). The cylinder is a pressure vessel and is not recommended as a mounting point, the cylinder should not be drilled, machined, mutilated or damaged in any way, any warranty could be invalidated by such actions.

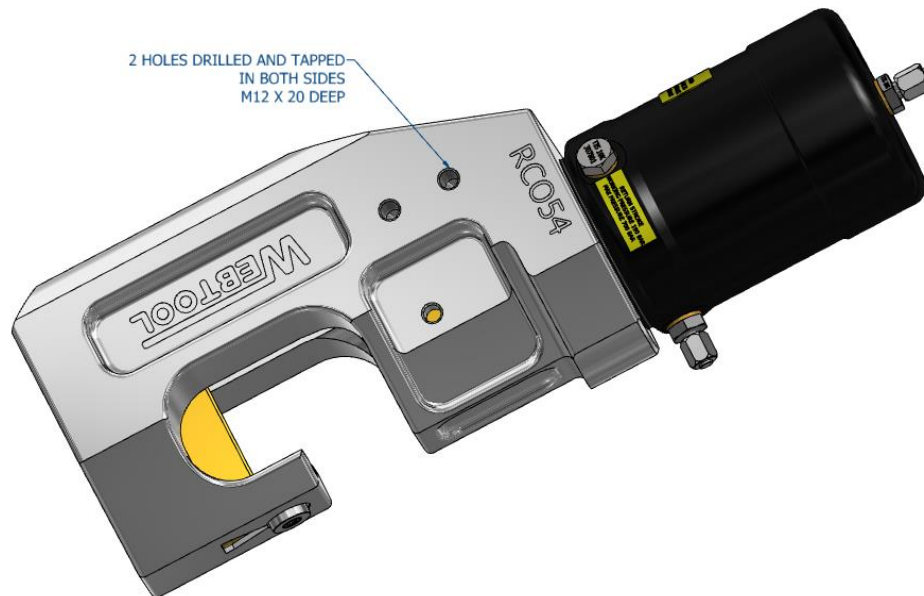

A hydraulic supply is required, ported as shown (see below). The maximum working pressures are shown in the table 1 below and pressure limiting valves must be fitted into the supply to limit the pressures to these levels.

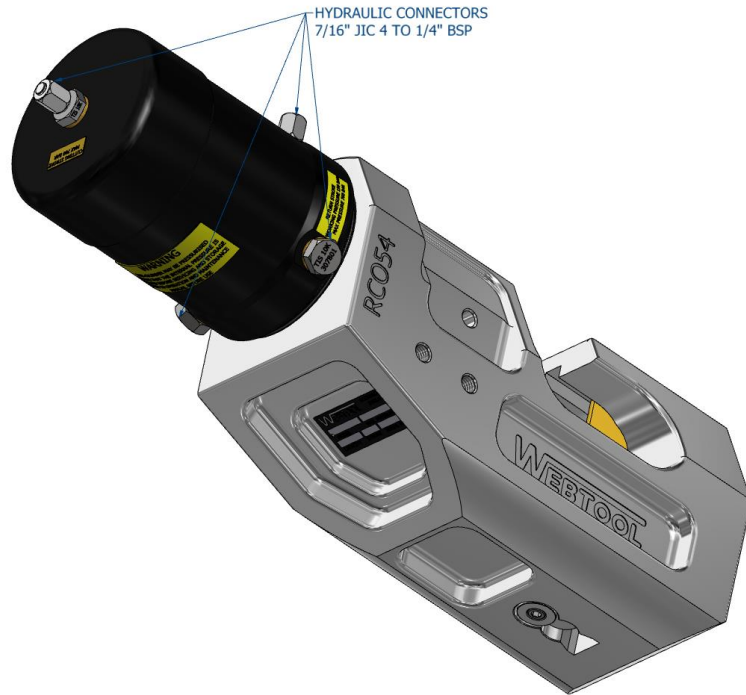

A relief valve should also be incorporated in the return line. This is to prevent excessively high pressures in the annular side of the hydraulic cylinders should the return to tank become blocked for any reason.

The oil supply must be clear and free from contamination. A good quality ISO32 grade hydraulic oil, e.g. Shell Tellus 32 or equivalent, is suitable.

The weight of the tool in air is approx. 37.4Kg

The weight of the tool in water is approx. 32.6Kg

(These approx. weights do not include oil)

TABLE 1:

Function	Max Working Pressure		Swept Volume	
	psi	bar	ml.	U.S. Gallon
Working Stroke	10,000	700	660	(0.174)
	10,000	700	250	(0.066)

Please note: Return stroke can be operated at 210 bar

4. OPERATION

Before deployment, function test the tool and ensure that all operators are familiar with this procedure. ROV observation of the tool should be maintained at all time during operation.

Prior to use, ensure no damage has occurred to the blade or anvil.

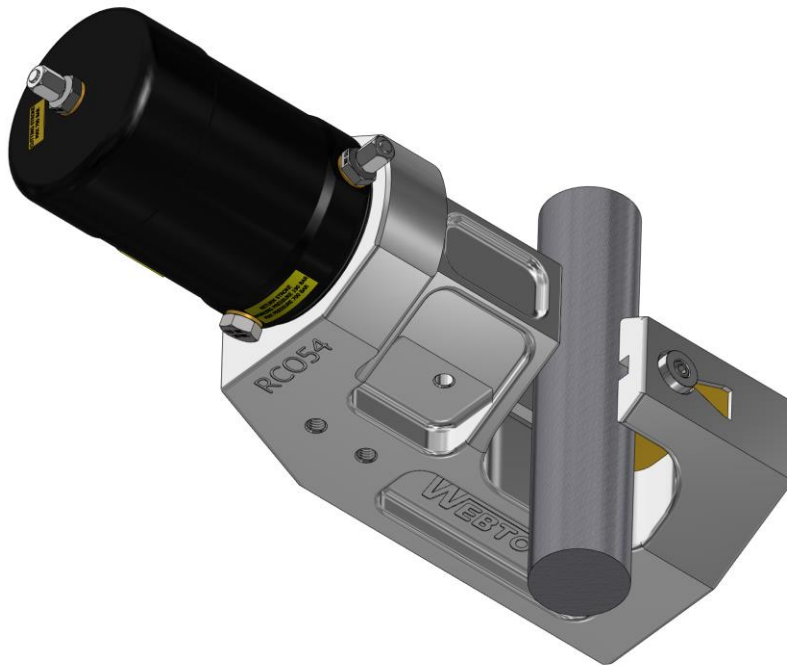

DEPLOYMENT

Place the wire rope in the cutter. Ensure that the wire rope is as far into the cutter as possible.

Operate the main ram power port to sever the wire rope, hold pressure until the wire rope is severed.

Once the wire is severed, pressurize the main ram retract port to withdraw the cutting blade.

Do not try to remove the anvil when the blade is fully extended.

If a further cut is required, the above procedure should be repeated.

Important: Please note this tool is designed for intermittent subsea use. Please refer to the manufacturer (Allspeeds Ltd) or an authorised distributor should you wish to use this tool subsea for any period over 14 days.

TROUBLESHOOTING

If the rope does not cut through completely on the first attempt, cycle the blade by retracting it slightly and then attempting the cut again.

If the rope does not completely cut after multiple cycles of the blade, check the input pressure

to the main input of the cylinder. This can be a maximum of 700 bar (10,000psi).

If the rope to be cut is still not severed after multiple cycles and at a pressure of 700 bar, retract the blade and then remove the anvil and return the tool to the surface for inspection of the blade and anvil, replace if necessary.

IMPORTANT NOTE – ENSURE THAT THE BLADE IS FULLY RETRACTED AND THAT ALL PRESSURE TO THE CUTTER IS RELIEVED AS IT IS RAISED TO THE SURFACE. FAILURE TO DO THIS CAN LEAD TO A DANGEROUS BUILD UP OF PRESSURE IN THE CYLINDER.

5. AFTER USE

When the tool is retrieved from a marine environment, it should be hosed off with clean water, allowed to drain and sprayed externally with a de-watering fluid. Before storage, inspect the general condition of the tool. Particular attention should be paid to the anvil and blade. The anvil should be clean and free from any damage, the blade edge should be smooth and free from any serrations. Note that a slight ripple to the blade edge is acceptable and will not cause problems. Any minor damage can be smoothed off with an oil stone if necessary.

IMPORTANT – DO NOT STORE THE TOOL WITH A COMPLETELY SEALED CYLINDER AS PRESSURE MAY BUILD UP DUE TO TEMPERATURE CHANGES.

6. SERVICE

IMPORTANT – ENSURE THERE IS NO HYDRAULIC PRESSURE IN THE CYLINDER BEFORE PERFORMING ANY SERVICE OR MAINTENANCE PROCEDURES ON THIS CUTTER

It is unlikely that service would be required on the hydraulic components of the tool under normal circumstances, but a seal spares kit is available if required. The only parts that would need intermittent replacement are the anvil and blade, depending on the frequency of use and materials being cut. These parts can be ordered up on the following spares reference numbers, but in addition please quote the tool serial number.

Seal Kit	Part Number	995169
Anvil	Part Number	761324
Blade	Part Number	705079C
Blade Retaining Pin	Part Number	030522

We advise that any servicing should be carried out by an authorised distributor only. If required, the tool can be returned to the manufacturer for servicing and testing. If servicing is to be undertaken by the user, please see note on proof testing under SAFETY (Chapter 3), and the following:-

All servicing operations should be carried out in a clean environment to prevent contamination of the oil and mating components.

Care should be taken with all mating areas i.e. threads and sealing faces, as any damage or abrasive contamination could cause galling or seizing on re-assembly.

Please note that we coat the steel cylinders with a Nitrotec coating for protection and to prevent galling, however, a suitable anti-galling paste should be used (we recommend Swagelok Silver Goop) on all stainless steel threads i.e. those on the body.

The cylinder is a pressure vessel and should not be drilled, machined, mutilated or damaged in any way for mounting purposes or to assist in its removal for servicing, any warranty could be invalidated by such actions.

7. REPLACEMENT OF THE ANVIL

Remove the screw (035110) in the front of the cutter and the retaining cap (080617), this will allow the anvil (761324) to be removed from the cutter. If the anvil doesn't come out freely remove the stop stud (079047) and retaining cap (080617) at the back of the cutter held in by one screw (035110) and tap out the anvil.

Assembly is the reverse of the above process.

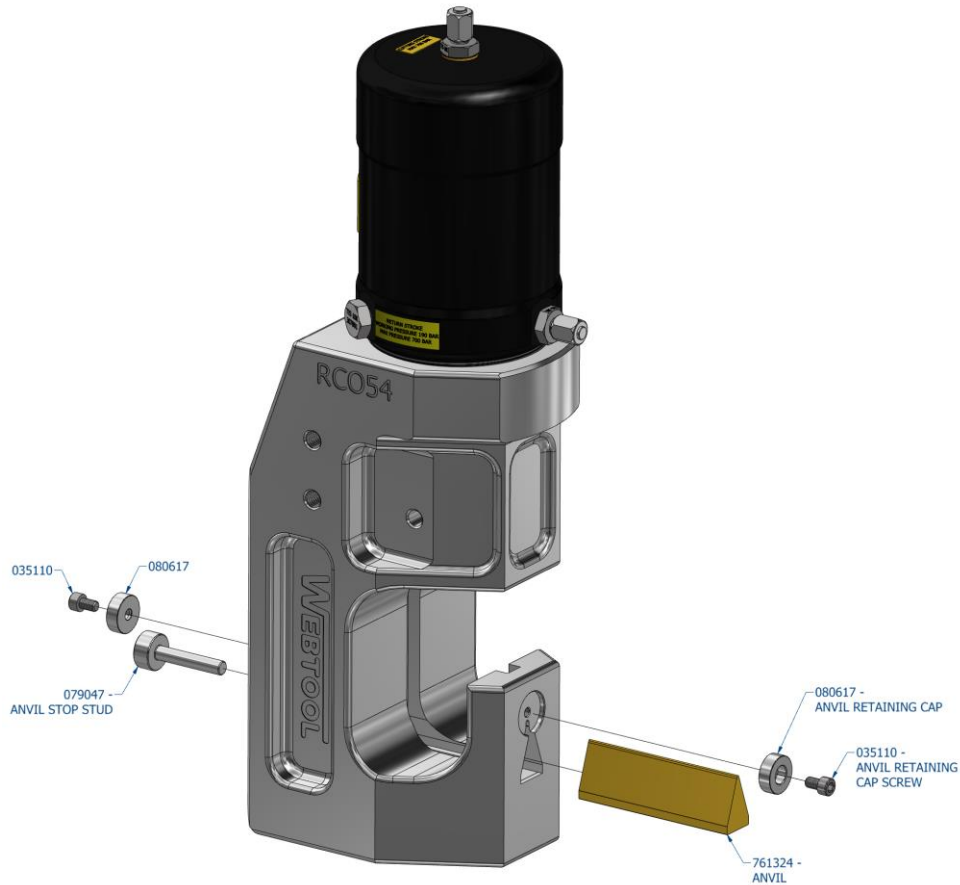

8. REPLACEMENT OF THE CUTTING BLADE

First withdraw the anvil as described above.

Pump out the main ram until the blade is level with the bottom of the side cutout for the mouth and the retaining pin (030522) can be seen in the hole in the cutter body. Drift out the pin (030522) and slide the blade (705079C) out of the tool.

Gloves should be worn to protect the hands when removing the blade from the tool.

When refitting the new blade ensure the retaining pin is fully contained within the piston outer diameter.

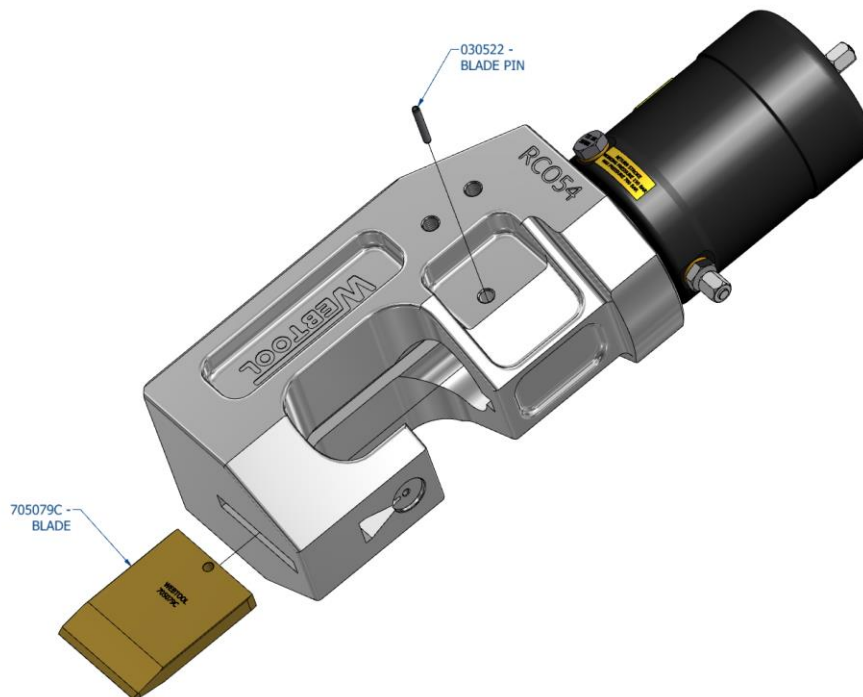

9. REMOVAL OF THE MAIN CYLINDER

If it is necessary to renew the hydraulic seals, first remove the blade as described above in section 8, the cylinder must then be removed from the tool. The hydraulic ports used by 791157 and blanking plug 766100 on the sides of the cylinder 728124 must be used. The hydraulic fittings should first be removed (ensure the cylinder is free from pressure), then fit the cylinder assembly ring (778017) with the ¼" BSP Location Screws (035170). Ensure that the ¼" BSP screws tighten and bottom out on the cylinder port faces. Once the ring is secured to the cylinder, screw in the M12 handles (748072) and turn. This method should be used to ensure a torque and not a bending moment is applied when screwing the cylinder into and out of the body.

The cylinder is a pressure vessel and should not be drilled, machined, mutilated or damaged in any way for mounting purposes or to assist in its removal for servicing, any warranty could be invalidated by such actions. The use of a Stilson wrench to remove the cylinder is not recommended as damage will occur.

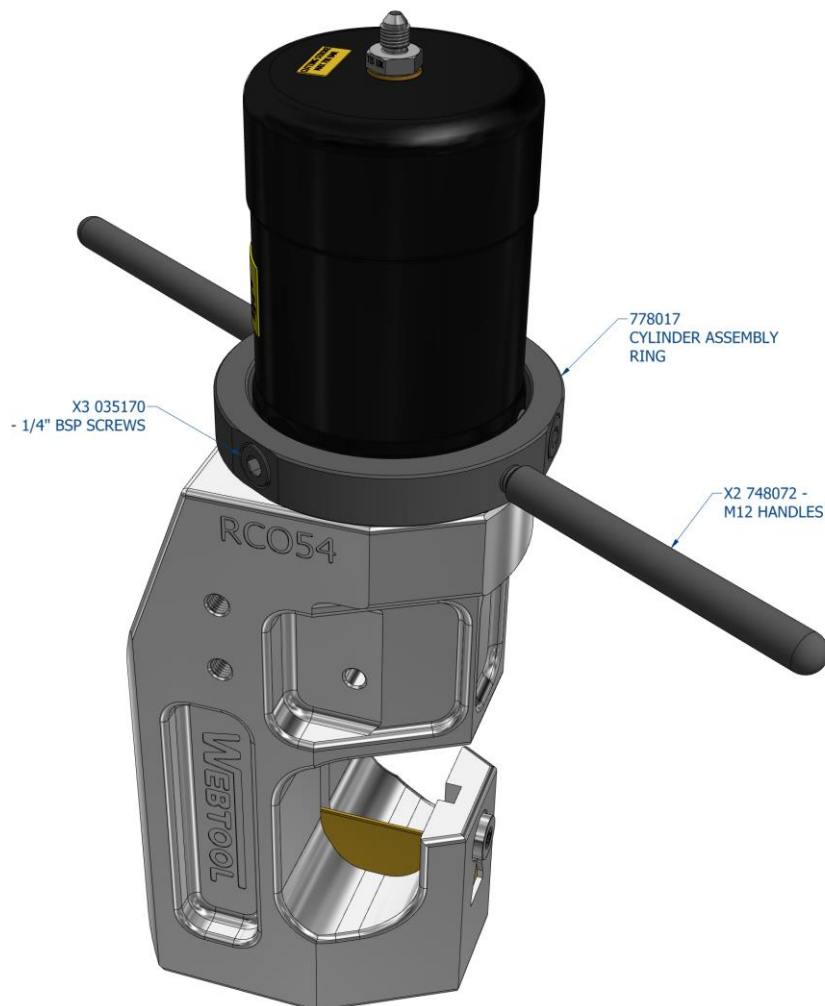

Cylinder assembly ring with ¼" BSP location screws and handles attached.

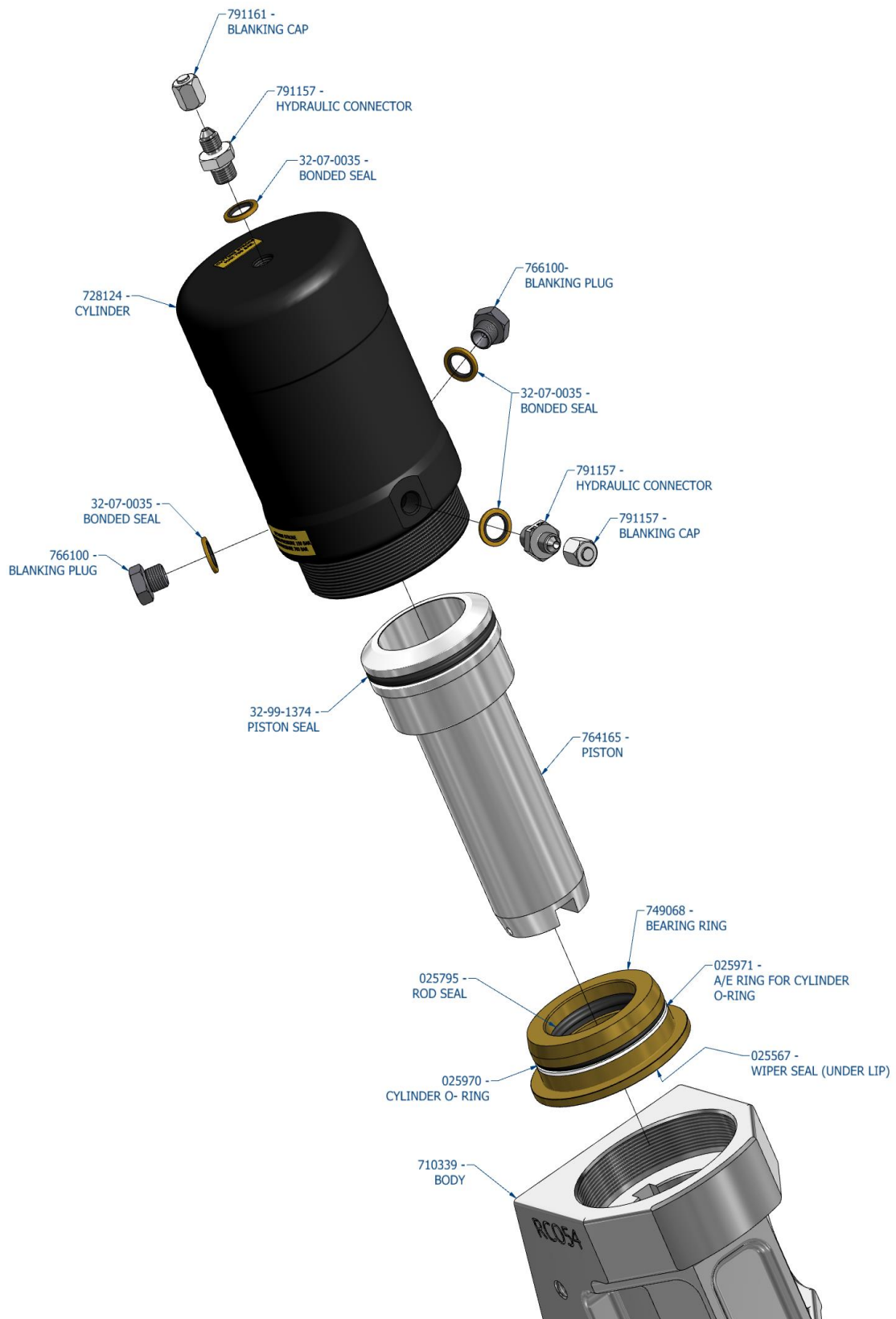

PARTS LIST				
	ITEM	QTY	PART NUMBER	DESCRIPTION
#	1	1	025795	RAM SEAL
#	2	1	025567	RAM WIPER SEAL
#	3	1	32-99-1374	PISTON SEAL
#	4	4	32-07-0035	BONDED SEAL 1/4" BSP
	5	1	030522	SPRING PIN - 3/16" x 1-3/8"
	6	2	791157	1/4" BSPP TO JIC 4 STRAIGHT ADAPTOR
	7	2	752574 R57	PORT PRESSURE LABEL - RETURN STROKE
	8	1	752573 R55.5	PRESSURE WARNING LABEL
	9	1	752342	WEBTOOL NAMEPLATE
	10	2	035110	STAINLESS CAP SCREW, M6 X 10
	11	2	766100	1/4" BSPP BLANKING PLUG
	12	1	752571	PORT PRESSURE LABEL - CUTTING STROKE
	13	1	728124	CYLINDER
	14	1	764165	PISTON
	15	1	749068	BEARING RING
	16	2	080617	ANVIL RETAINING CAP
	18	1	761324	ANVIL
	21	1	710339	BODY
#	22	1	025970	CYLINDER O-RING
#	23	1	025971	A/E RING FOR CYLINDER O-RING
	24	1	705079C	BLADE
	25	2	791161	JIC 4 MALE BLANKING PLUG
	26	1	079047	ANVIL STOP STUD

= SEAL KIT ITEMS (995196)

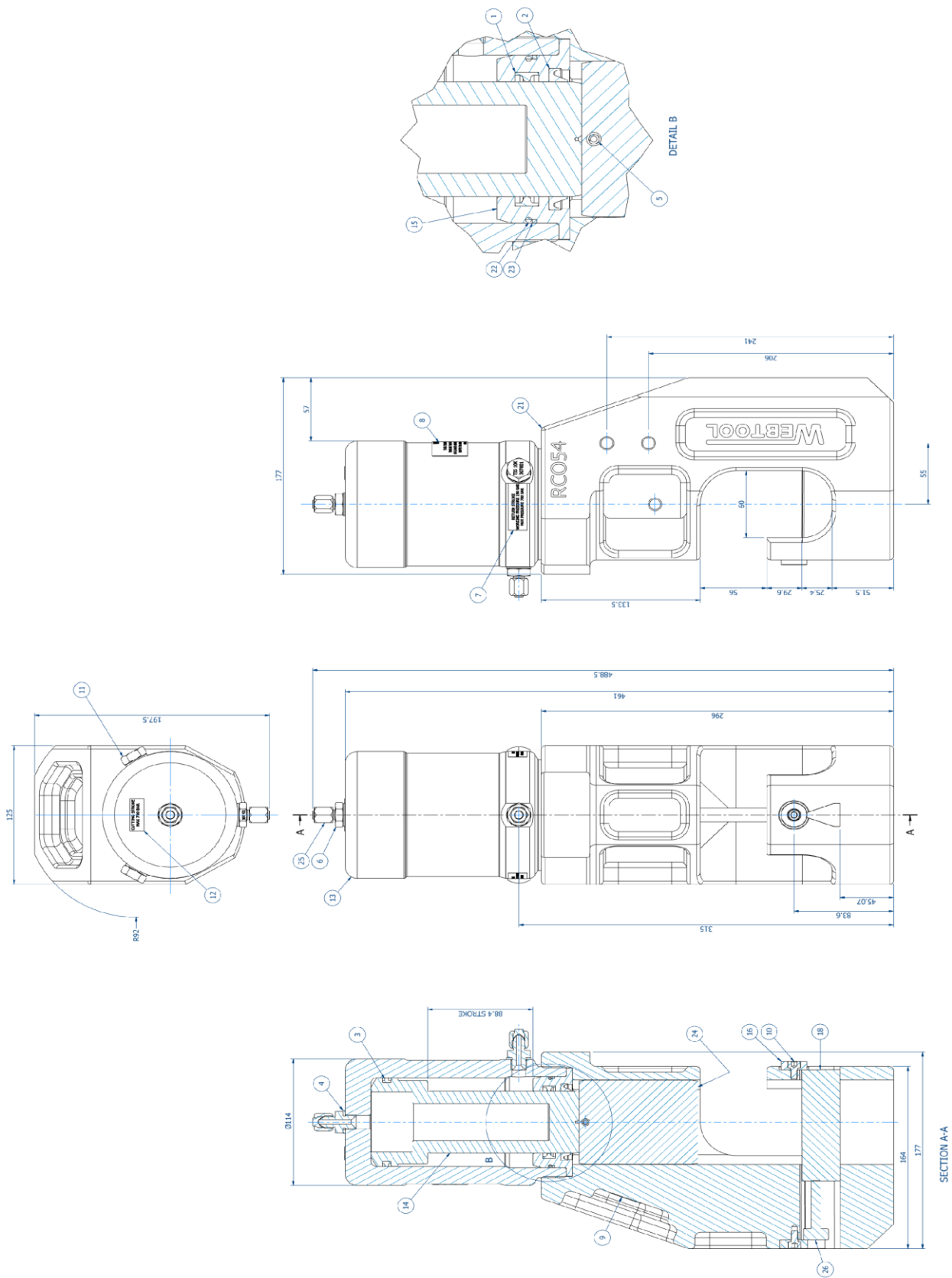

This RCO54 Wire Rope Cutter is compatible with the following optional extras (not supplied as standard):

Handle Assembly - 999024



Webtool Hydraulic Intensifier – HP690A (available in a range on intensification ratios)



For further information contact the manufacturer (Allspeeds Ltd) or an authorised distributor.



CUTTING EDGE TECHNOLOGY

Webtool specialises in engineering powerful hydraulic tools for cutting and gripping rope, cable and umbilicals.

Models designed for use in subsea environments by ROV's, and surface applications in hostile environments.

- Wire rope cutters (WCS and WCOS) – capable of cutting steel wire rope up to 75mm diameter
- Wire Rope Cutters (RCV) – capable of cutting steel wire rope up to 190mm diameter
- Cable Cutters (HCV) – capable of cutting cable, umbilical and armoured flexible pipe lines up to 330mm diameter
- Softline Cutters (SL) – capable of cutting fibre ropes in various sizes
 - Wire Rope / Cable Grippers
 - Wire Rope Clamps
 - Automatic Shackles

Application specific solutions

Our in house design and manufacturing capability means we can quickly and efficiently develop a solution to suit your particular application. Contact our engineering department to discuss how we can help.

Allspeeds Ltd, Royal Works, Atlas Street, Clayton-Le-Moors,
Accrington, Lancashire, BB5 5LW, England

T: +44 (0)1254 615100

F: +44 (0)1254 615199

E: info@allspeeds.co.uk

W: www.allspeeds.co.uk