



Allspeeds Ltd.  
Royal Works, Atlas St  
Clayton le Moors  
Accrington  
Lancashire  
England  
BB5 5LW

Tel +44 (0)1254 615100  
[www.allspeeds.co.uk](http://www.allspeeds.co.uk)

**WIRE ROPE CUTTER RCV115**

**PRODUCT CODE No. 980290**

**INSTRUCTIONS FOR INSTALLATION,  
OPERATION & MAINTENANCE**

Revision 12 issue 7. Modification No. 20972 Date 14<sup>th</sup> November 2017

© Copyright Allspeeds Holdings Ltd.  
**This document must not be modified in any way.**

## Description

This cutter is primarily intended for use on steel wire rope, having a maximum tensile strength of 1770N/mm up to 115mm diameter. It may be used on alternative materials, such as electrical power or communication cables, again up to a maximum of 115mm diameter. Where smaller diameters are to be cut, effort should be made to place the material centrally along the anvil to minimise any offset loading.

### IMPORTANT

If it is required to extend the recommended use of the cutter, for instance to cut solid steel bar or wire rope with a greater strength, please refer to the manufacturer, Allspeeds Ltd, with full details of material size and tensile strength. Cutting unsuitable materials could result in damage to the tool.

### 1. SAFETY

Before operation, read and understand this operations manual.

Whilst the tool is intended for remote or local operation sub-sea, there is no reason why it should not be used above surface.

Ensure that the tool, hoses and pump are in good condition and properly connected.

Ensure that suitable pressure regulation equipment is used and that the unit is not subjected to pressures higher than those stated in section 3

In all cases, where an operator is present, the safety aspects must be reviewed before the cutting operation is commenced.

No attempt should be made to cut any material that is under tension.

Ensure that the operator is shielded from the cutting blade during the cutting operation.

When cutting near the very end of hose fragments can be expelled from the tool, please ensure that the operator is shielded from these.

If in doubt please contact the manufacturer (Allspeeds Ltd) or an authorized distributor for assistance.

If at any time it is necessary to carry out proof tests on the tool, e.g. after service on the hydraulic cylinders, it must be returned to the supplier for testing where the following procedures apply.

The maximum proof test pressure should not exceed 125% of the maximum working pressure and this should only be done by Allspeeds using our specially adapted test rig.

The tool should be guarded during the proof test operation, and be carried out in a safe working environment.

The proof pressure should be applied gradually, until the maximum pressure is reached.

**Important:** Please note this tool is designed for intermittent subsea use. Please refer to the manufacturer (Allspeeds Ltd) or an authorized distributor should you wish to use this tool subsea for any period over 14 days.

**CAUTION** – Any modification made to this tool will invalidate the warranty and may lead to equipment failure or personal injury. If in doubt please contact the manufacturer (Allspeeds Ltd) or an authorised distributor for assistance.

### **INSPECT THE TOOL BEFORE USE**

With the cutter isolated from the hydraulic supply, check the condition of the blade edge. If the blade is damaged or blunt replace with a fresh blade before cutting. This procedure is as described in section 8.

Ensure that care is taken when checking the blade as the edge may be sharp

Check the condition of the anvil. It is normal that the anvil will show an indent where the blade has pressed down into it and can withstand multiple cuts, but any excessively damaged anvil should be replaced. This procedure is as described in section 7

### **CAUTION – USE OF BLADES AND PARTS NOT APPROVED BY WEBTOOL MAY RESULT IN TOOL FAILURE AND CONSEQUENTIAL DAMAGE**

## **2. CUTTING CAPACITY**

The cutter is primarily intended for use on steel wire rope, having a maximum tensile strength of 1770N/mm and will cut ropes up to 115mm diameter. It may be used on alternative materials, such as electrical power or communication cables, again up to a maximum of 115mm diameter. Where smaller diameters are to be cut, effort should be made to place the material centrally along the anvil to minimise any offset loading.

## **3. INSTALLATION**

Tapped Holes, M12, are provided in the tool body (see sketch) which can be used for any attachment necessary to mount the cutter. The cylinder is a pressure vessel and is not recommended as a mounting point, the cylinder should not be drilled, machined, mutilated or damaged in any way, any warranty could be invalidated by such actions.

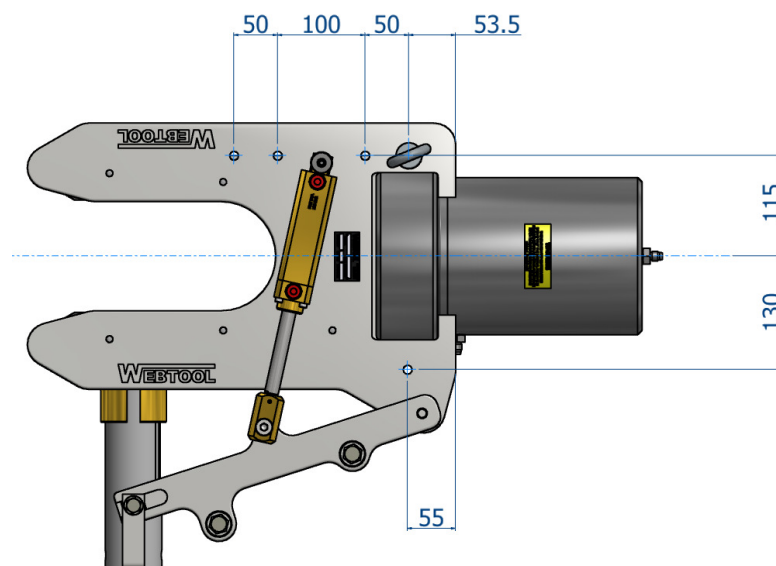

Two hydraulic supplies are required, ported as shown below. The maximum working pressures are shown in the table below and pressure limiting valves must be fitted into the supply to limit the pressures to these levels. The weight of the tool is 125kg.

**TABLE 1.**

| Function   | Max. Working Pressure |      | Swept Volume |             | Port Tapping |
|--|-----------------------|------|--------------|-------------|--------------|
|  | psi                   | bar  | ml.          | U.S. Gallon |              |
| Main Ram Working Stroke                              | 10,000                | 690  | 2125         | (0.561)     | 3/8" NPT     |
| Main Ram Return Stroke                               | 10,000*               | 690* | 810          | (0.214)     | 3/8" NPT     |
| Auxiliary Cylinders Out Stroke<br>(to retract anvil) | 2,750                 | 190  | 100          | (0.026)     | 1/4" NPT     |
| Auxiliary Cylinders Instroke<br>(to reset anvil)     | 2,750                 | 190  | 60           | (0.016)     | 1/4" NPT     |

**\*N.B.** Actual pressure required to return Ram < 200 psi (14 bar)

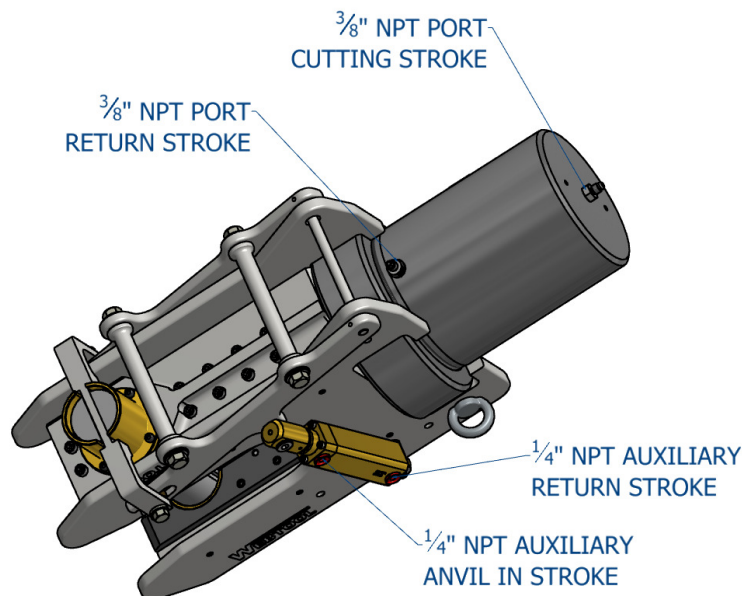

#### **4. OPERATION**

Before deployment, function test the tool and ensure that all operators are familiar with this procedure. ROV observation of the tool should be maintained at all time during operation. Prior to use, ensure no damage has occurred to the blade or anvil. Ensure the anvil is fully retracted.

##### **DEPLOYMENT**

Prior to use, the auxiliary cylinder outstroke should be operated to withdraw the anvil. This clears access for the cutter to be placed over the wire rope. Place the cutter over the wire rope. Ensure that the wire rope is as far into the cutter as possible so that the anvil does not foul as it is reset. Place the cutter over the wire rope. Ensure that the wire rope is as far into the cutter as possible

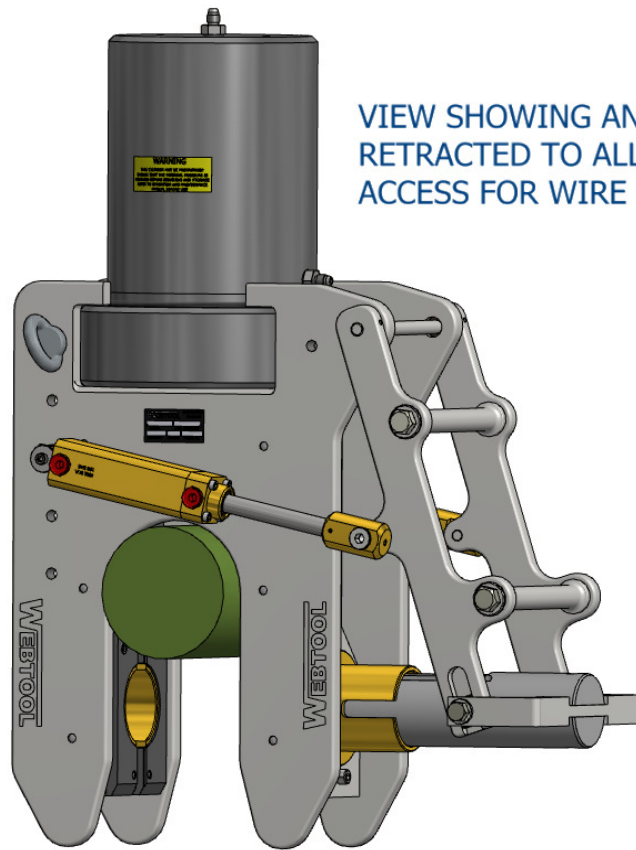

VIEW SHOWING ANVIL FULLY  
RETRACTED TO ALLOW  
ACCESS FOR WIRE ROPE

Operate the auxiliary cylinder in stroke to position the anvil fully home under the wire rope, the main ram should not be activated until the auxiliary cylinders are operated to the full extent of their stroke.

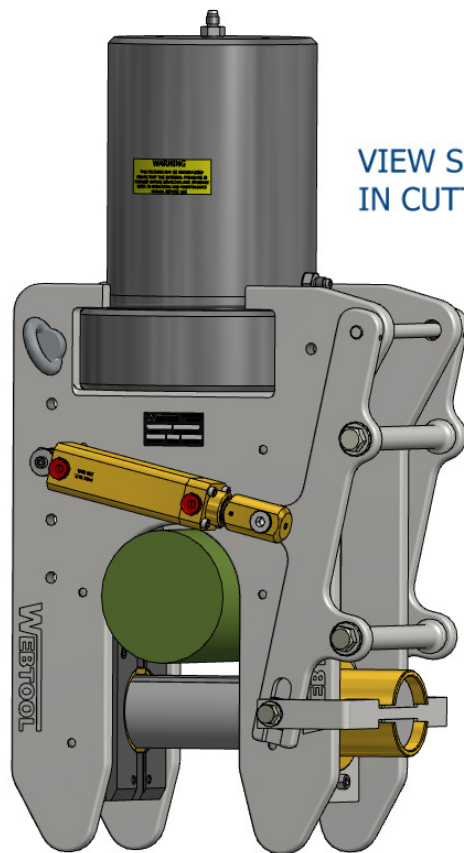

VIEW SHOWING ANVIL  
IN CUTTING POSITION

Operate the main ram down-stroke to sever the wire rope. Once the wire rope is severed, Pressurize the main ram retract port to withdraw the cutting blade. Then, and only then, retract the anvil. It is important not to operate the anvil cylinder whilst the main ram and blade are in the fully extended position.

If a further cut is required, the above procedure should be repeated.

**N.B.** Do not operate the auxiliary cylinders when the main ram is fully extended since this would damage the anvil.

## **TROUBLESHOOTING**

If the wire rope does not cut through completely on the first attempt, cycle the blade by retracting it slightly and then attempting the cut again.

If the wire rope does not completely cut after multiple cycles of the blade, check the Input pressure to the main input of the cylinder. This can be a maximum of 700 bar (10,000psi).

If the wire rope to be cut is still not severed after multiple cycles and at a pressure of 700 bar, Retract the blade and then the anvil and return the tool to the surface for inspection of the blade and anvil, replace if necessary.

**IMPORTANT NOTE – ENSURE THAT THE BLADE IS FULLY RETRACTED AND THAT ALL PRESSURE TO THE CUTTER IS RELIEVED AS IT IS RAISED TO THE SURFACE. FAILURE TO DO THIS CAN LEAD TO A DANGEROUS BUILD UP OF PRESSURE IN THE CYLINDER.**

## **5. AFTER USE**

When the tool is retrieved, it should be hosed off with clean water, allowed to drain and sprayed externally with a de-watering fluid. Before storage, inspect the general condition of the tool. Particular attention should be paid to the anvil and blade. The anvil should be clean and free from any damage or bruising on the outside diameter that would prevent it from retracting properly. The blade edge should be smooth and free from any serrations. Note that a slight ripple to the blade edge is acceptable and will not cause problems. Any minor damage can be smoothed off with an oil stone if necessary.

## **6. SERVICE**

It is unlikely that service would be required on the hydraulic components of the tool under normal circumstances, but a seal spares kit is available if required. The only parts that would need intermittent replacement would be the anvil, blade and wear plates, depending on the frequency of use and materials being cut. These parts can be ordered up on the following spares reference numbers, but in addition please quote the tool serial number.

|                       |             |                |
|-----------------------|-------------|----------------|
| <b>Seal Kit</b>       | Part Number | <b>995290</b>  |
| <b>Anvil</b>          | Part Number | <b>SSC6475</b> |
| <b>Blade</b>          | Part Number | <b>705036C</b> |
| <b>Wear Plate Kit</b> | Part Number | <b>995079</b>  |

We advise that any servicing should be carried out by an authorised distributor only.

If required, the tool can be returned to the manufacturer, Allspeeds Ltd, for servicing and testing.

If servicing is to be undertaken by the user, please see note on proof testing under SAFETY (Chapter 1), and the following:-

All servicing operations should be carried out in a clean environment to prevent contamination of the oil and mating components.

Care should be taken with all mating areas ie. threads and sealing faces, as any damage or abrasive contamination could cause galling or seizing on re-assembly.

The cylinder is a pressure vessel and should not be drilled, machined, mutilated or damaged in any way for mounting purposes or to assist in its removal for servicing, any warranty could be invalidated by such actions.

The use of stilsons to remove the cylinder is not recommended as damage will occur.

**IMPORTANT:** Please note this tool is designed for intermittent subsea use. Please refer to the manufacturer should you wish to use this tool subsea for any period over 14 days.

## 7. REPLACEMENT OF THE ANVIL

Remove the two Sliding Block Screws, Washers and Sliding Blocks 035082, 080956 and 709047  
The Anvil SSC6475 can now be removed attached to the Anvil Bracket 765174, knock out the Slotted Spring Pin 030820 this will disconnect the Anvil Bracket and free the Anvil  
Re assembly is the reverse of the above.

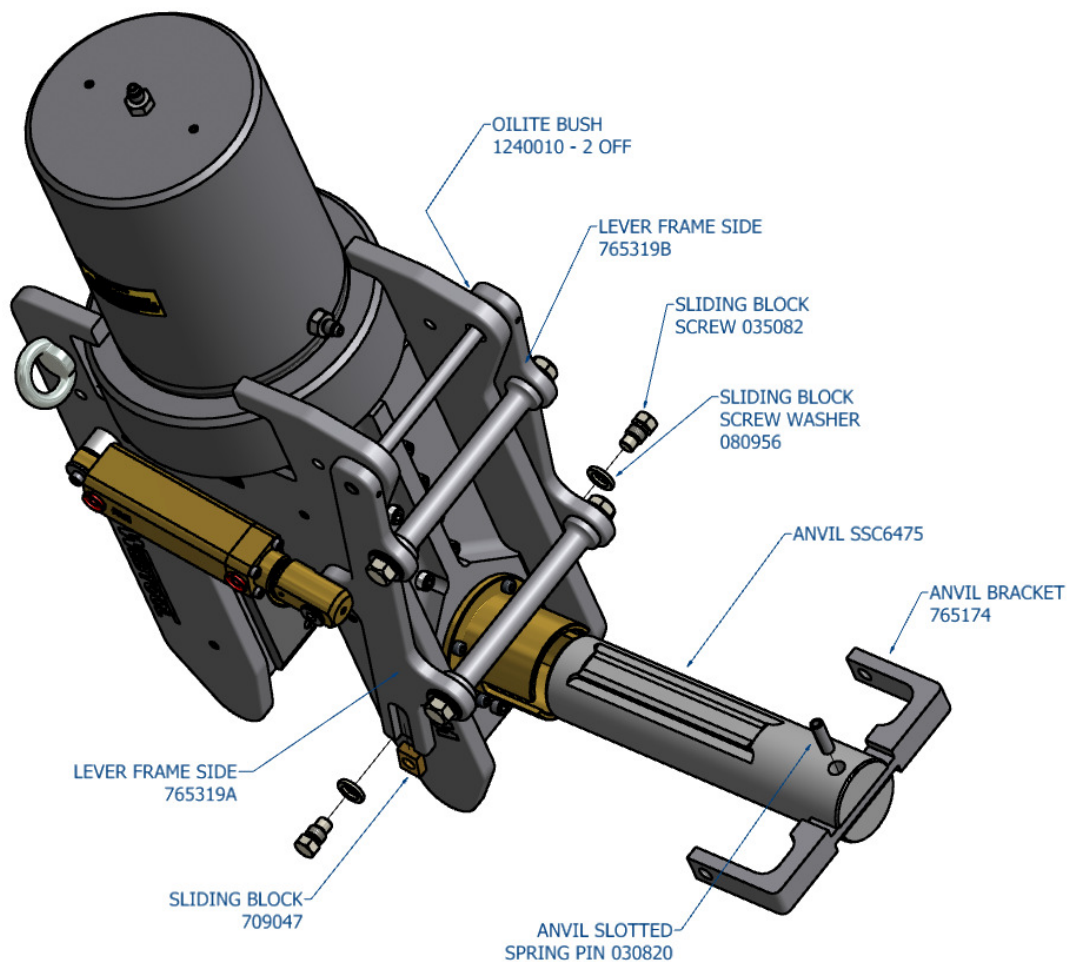

## 8. REPLACEMENT OF THE CUTTING BLADE

First withdraw the anvil as shown below by applying pressure to the auxiliary ports. Pump out the main ram until the blade spring pins 030636 can be seen in the opening of the cutter body.

The two pins are ¼" (6.35mm) diameter and they should be knocked out enough to release the blade.

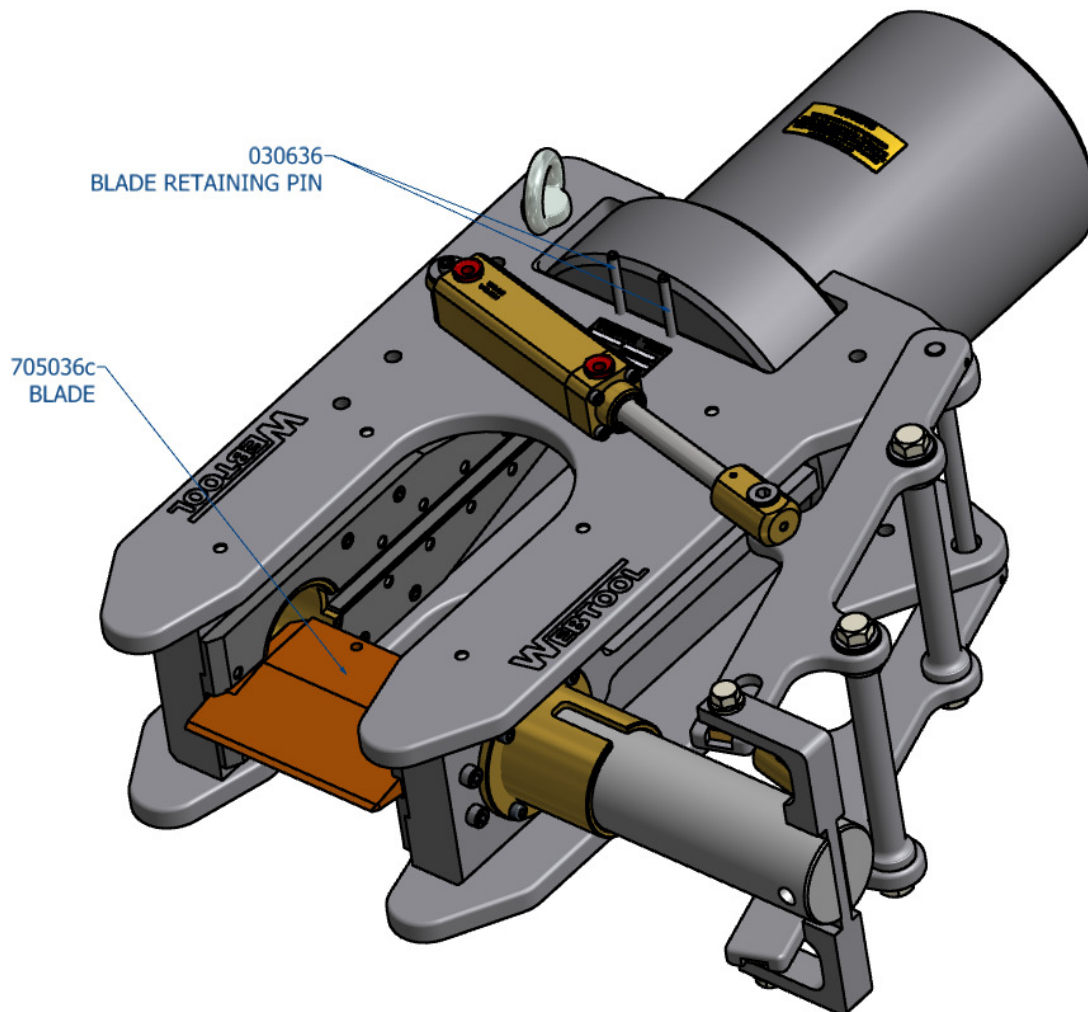

With the pins removed the blade can be taken from the cutter, gloves should be worn to prevent cuts from any sharp edges that may be present on the blade after use. Re-assembly is the reverse of the above process.

## 9. REMOVAL OF THE MAIN CYLINDER

If it is necessary to renew the hydraulic seals, the cylinder must be removed from the tool. As an aid to this, 2 off tapped holes are provided in the cylinder end face. These are M8 x 8 deep on 100mm centres.

First, pump out the ram and remove the blade, again as described above in section 8.

To use the holes in the top of the cylinder first remove any couplings, then the blanking screws 035081 and fasten a piece of flat bar, typically 30x10mm section and 900mm long centrally to the top of the cylinder. This can be used to loosen or re-tighten the cylinder. Do not use Stilson's to remove the cylinder as damage will occur.



Unscrew the cylinder 728060 and remove from the assembly, it will come free but still attached will be the ram 764098.

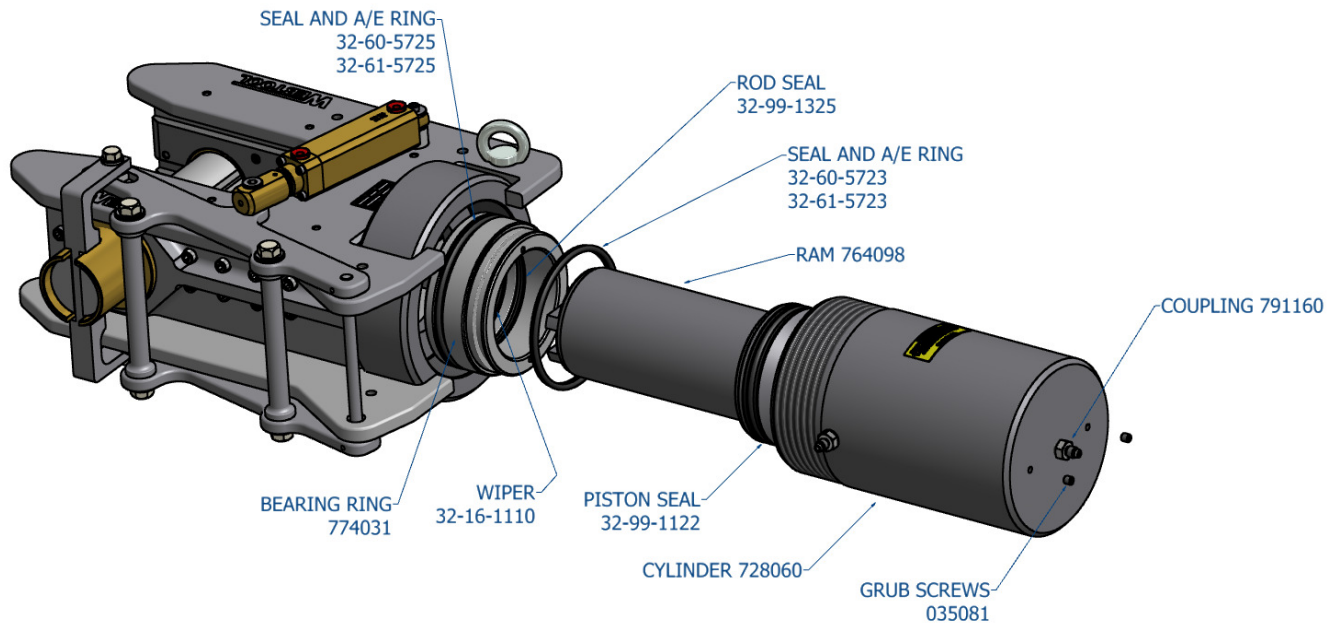

Put the assembled parts into a plastic dust bin or similar vessel, fit the coupling to the top of the cylinder, attach a hand pump to the coupling and pump out the ram, importantly, **by hand**. The ram will now be free of the cylinder and all seals will be accessible.

To re assemble, fit the ram into the assembly, locate the blade and fit the spring pins, put grease on the threads and screw in the cylinder using the two tapped holes and the flat bar, remove the bar, replace the screws and fit the coupling and bonded seal. The tool is now ready for use.

Views below shows other components in the cutter not previously mentioned with their part numbers.

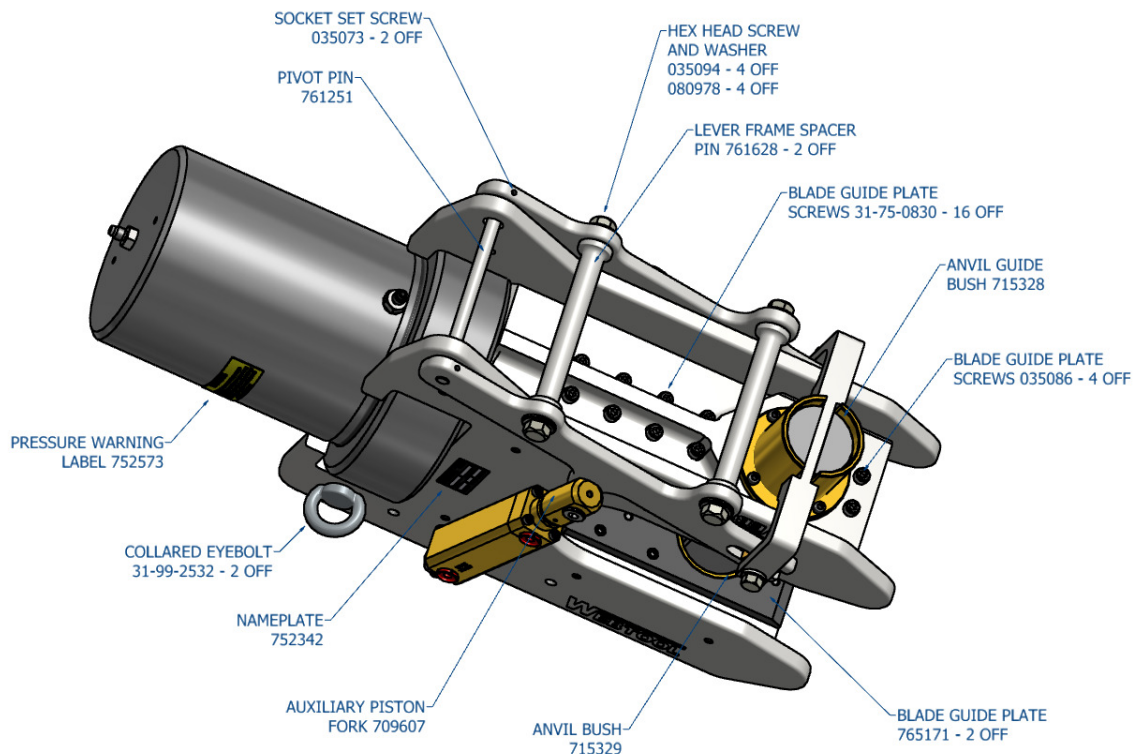

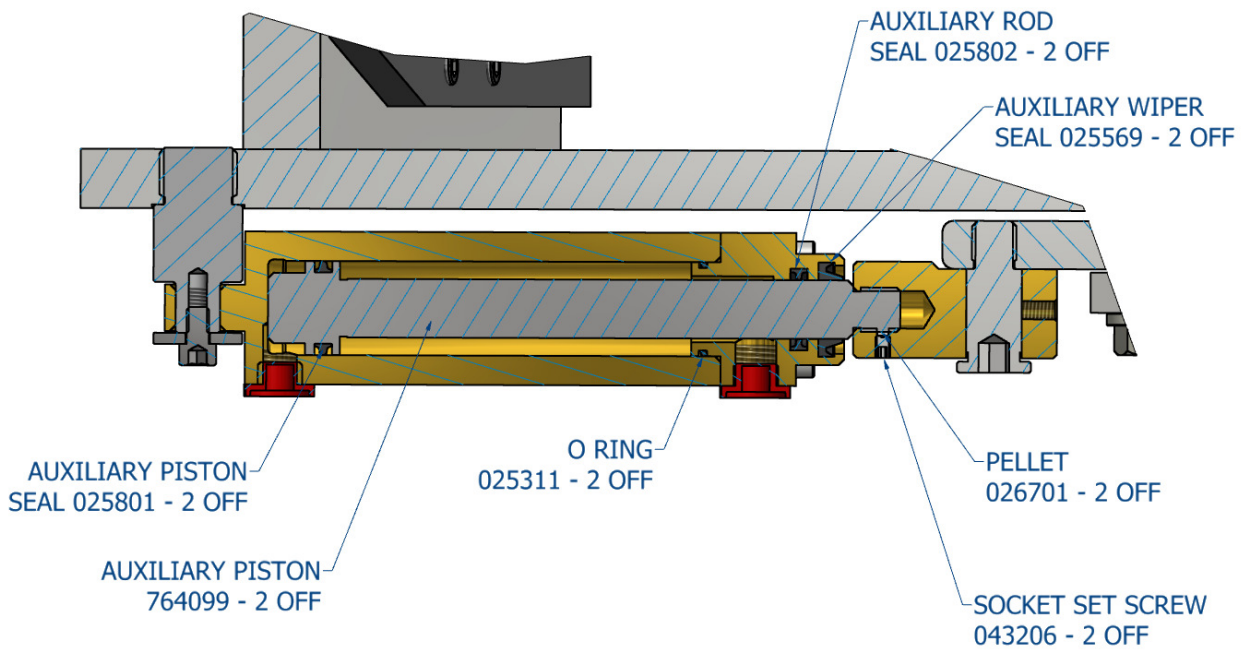
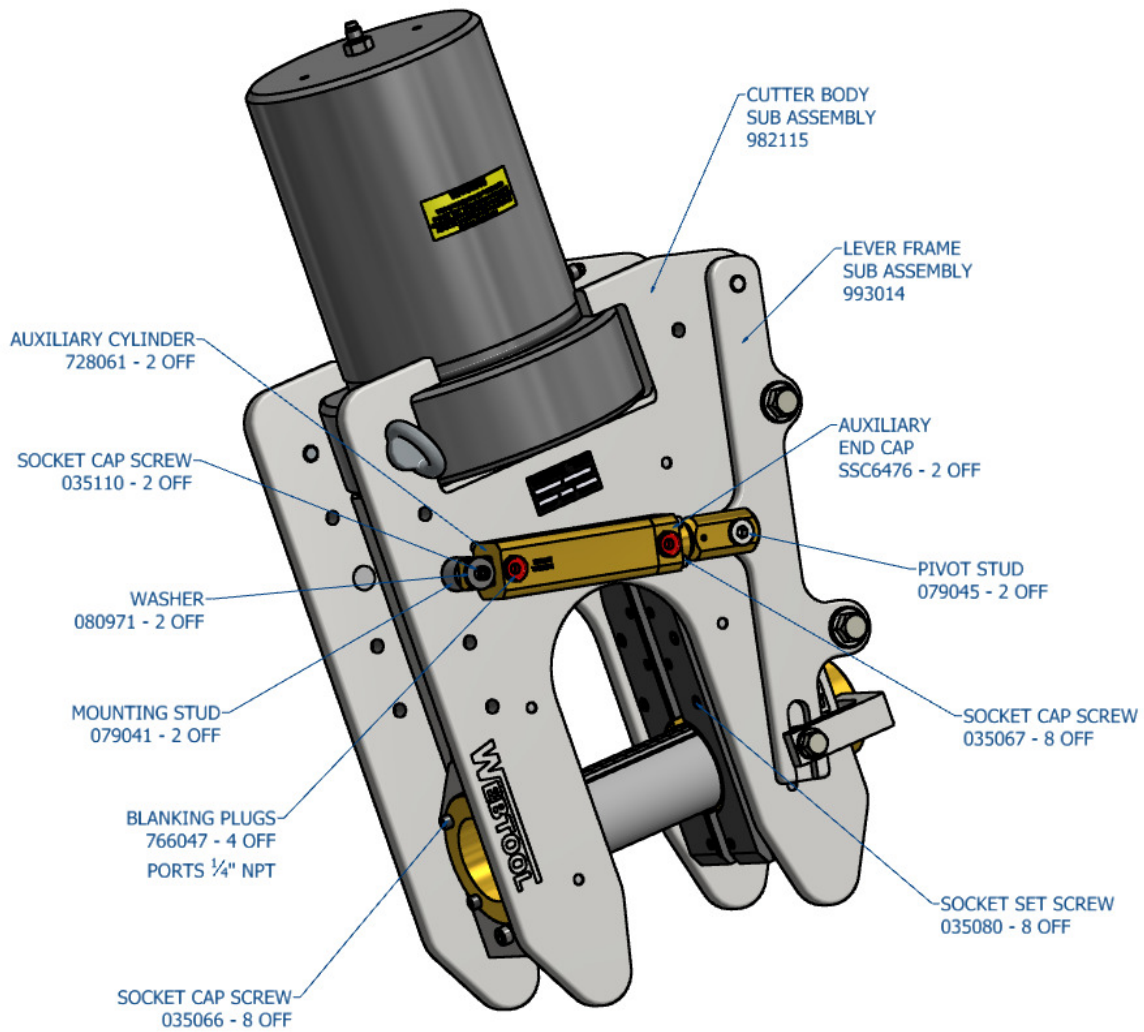

This RC115 cutter is compatible with the following optional extras, not supplied as standard.

A set of thicker wear plates **995148** are available and shown below, these would replace the existing wear plates and reduce the width of the throat of the cutter by 40mm to ensure that the item being cut would be held central to the cutter

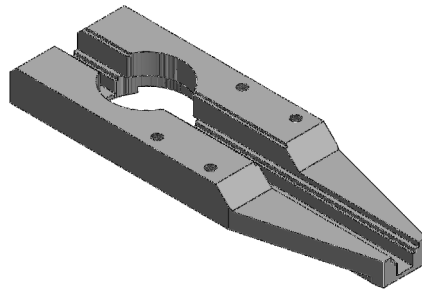

**Cylinder Assembly Tool - SK4377A**

This tool can be used on RCV75, RCV75HD, RCV115, RCV135, RCV155, RCV190, HCV100, HCV120, HCV250 and HCV270 cutting tools

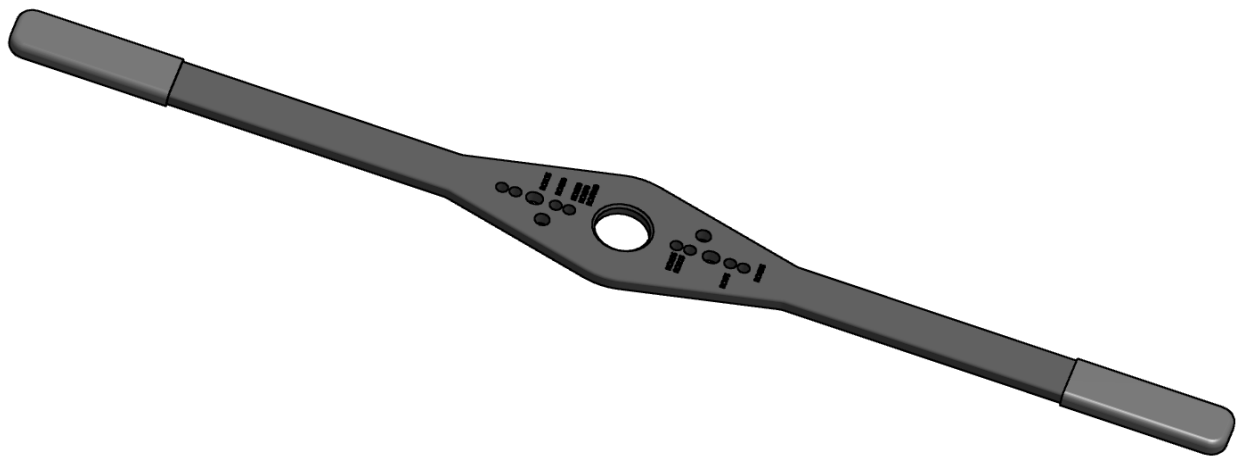

**Webtool Hydraulic Intensifier – HP690A** (available in a range on intensification ratios)



For further information contact the manufacturer (Allspeeds Ltd) or an authorised distributor

| <b>Lever Frame Sub Assembly</b> |   | <b>993014</b> |
|---------------------------------|---|---------------|
| <b>Part No.</b>                 | <b>Description</b>                          | <b>Qty</b>    |
| 030820                          | Anvil spring pin                            | 1             |
| 035073                          | Socket cap screw M6 x 10 stainless steel    | 2             |
| 035082                          | Sliding block screw                         | 2             |
| 035094                          | Hexagon head screw M10 x 20 stainless steel | 4             |
| 043206                          | Socket set cup point M4 x 6 stainless steel | 2             |
| 080956                          | Washer – sliding block screw                | 2             |
| 080978                          | Lever frame washer                          | 4             |
| 709047                          | Sliding block                               | 2             |
| 709607                          | Auxiliary piston fork                       | 2             |
| 761251                          | Pivot pin Ø12mm x 190mm long                | 1             |
| 761628                          | Lever frame spacer pin                      | 2             |
| 765174                          | Anvil bracket                               | 1             |
| 765319A                         | Lever frame side plate A                    | 1             |
| 765319B                         | Lever frame side plate B                    | 1             |

| <b>RCV 115 – Full Part List excluding seals</b> |   | <b>980290</b> |
|---|---|---------------|
| <b>Part No.</b>                                 | <b>Description</b>                      | <b>Qty.</b>   |
| 728060  | Cylinder                                | 1             |
| 764098  | Ram                                     | 1             |
| 765171  | Blade guide plate                       | 2             |
| SSC6475   | Anvil                                   | 1             |
| 774031  | Bearing ring                            | 1             |
| 705036c   | Blade                                   | 1             |
| 715328  | Anvil guide bush                        | 1             |
| 715329  | Anvil bush                              | 1             |
| 079041  | Mounting stud                           | 2             |
| 079045  | Pivot stud for auxiliary                | 2             |
| 080971  | Special washer M6                       | 2             |
| 035066  | Socket cap screw M6 x 20 stainless 316  | 8             |
| 035110  | Socket cap screw M6 x 10 stainless 316  | 2             |
| 035081  | Socket cap screw M8 x 8 stainless 316   | 2             |
| 31-75-0830                                      | Socket cap screw M8 x 30 stainless 316  | 16            |
| 035086  | Socket cap screw M8 x 50 stainless 316  | 4             |
| 035080  | Socket set screw M10 x 12 stainless 316 | 8             |
| 752342  | Nameplate                               | 1             |
| 766047  | Blanking plug                           | 4             |
| 791160  | Coupling                                | 2             |
| 791161  | Coupling Cap                            | 2             |
| 030636  | Spring pin ¼" x 2"                      | 2             |
| 31-99-2832                                      | Eye bolt M12                            | 2             |
| 1240010   | Oilite sintered bronze bush             | 2             |
| 752573  | Pressure warning label                  | 1             |
| 982116  | Auxiliary cylinder assembly             | 2             |
| 982115  | Body assembly                           | 1             |
| 993014  | Lever frame assembly                    | 1             |
| 995290  | Seal kit                                | 1             |

| <b>Seal Kit – Part List</b> |                                | <b>995290</b> |
|-----------------------------|--------------------------------|---------------|
| <b>Part No.</b>             | <b>Description</b>             | <b>Qty.</b>   |
| 025311                      | Seal, 'O' ring, end cap        | 2             |
| 025569                      | Scraper, rod                   | 2             |
| 025801                      | Seal, piston                   | 2             |
| 025802                      | Seal, rod                      | 2             |
| 32-99-1122                  | Main piston seal               | 1             |
| 32-99-1325                  | Main rod seal                  | 1             |
| 32-60-5723                  | Seal O ring 134.3mm i/dia      | 1             |
| 32-16-1110                  | Main wiper seal                | 1             |
| 32-61-5723                  | A/E ring for O ring            | 1             |
| 32-60-5725                  | Seal O ring 144.3mm i/dia      | 1             |
| 32-61-5725                  | A/E ring for O ring 32-60-5725 | 1             |

| <b>Auxiliary Cylinder Subassembly – Part List</b> |                          | <b>982116</b> |
|---|--------------------------|---------------|
| <b>Part No.</b>                                   | <b>Description</b>       | <b>Qty.</b>   |
| 728061  | Cylinder                 | 1             |
| SSC6476   | End cap                  | 1             |
| 764099  | Piston                   | 1             |
| 035067  | Socket cap screw M5 x 30 | 4             |
| 025311  | Seal, 'O' ring, end cap  | 1             |
| 025569  | Scraper, rod             | 1             |
| 025801  | Seal, piston             | 1             |
| 025802  | Seal, rod                | 1             |
| 026701  | Pellet                   | 1             |



## **CUTTING EDGE TECHNOLOGY**

Webtool specialises in engineering powerful hydraulic tools for cutting and gripping rope, cable and umbilicals.

Models designed for use in subsea environments by ROV's, and surface applications in hostile environments.

- Wire rope cutters (WCS and WCOS) – capable of cutting steel wire rope up to 75mm diameter
- Wire Rope Cutters (RCV) – capable of cutting steel wire rope up to 190mm diameter
- Cable Cutters (HCV) – capable of cutting cable, umbilical and armoured flexible pipe lines up to 330mm diameter
- Softline Cutters (SL) – capable of cutting fibre ropes in various sizes
  - Wire Rope / Cable Grippers
    - Wire Rope Clamps
    - Automatic Shackles

### **Application specific solutions**

Our in house design and manufacturing capability means we can quickly and efficiently develop a solution to suit your particular application. Contact our engineering department to discuss how we can help.

Allspeeds Ltd, Royal Works, Atlas Street, Clayton-Le-Moors,  
Accrington, Lancashire, BB5 5LW, England

T: +44 (0)1254 615100  
E: [info@allspeeds.co.uk](mailto:info@allspeeds.co.uk)

F: +44 (0)1254 615199  
W: [www.allspeeds.co.uk](http://www.allspeeds.co.uk)