



Allspeeds Ltd.
Royal Works, Atlas St
Clayton le Moors
Accrington
Lancashire
England
BB5 5LW

Tel +44 (0)1254 615100
www.allspeeds.co.uk

WIRE ROPE CUTTER RCV190

PRODUCT CODE No. 980230

**INSTRUCTIONS FOR INSTALLATION,
OPERATION & MAINTENANCE**

Revision 6 issue 2. Modification No. 20915 Date 13th September 2016

© Copyright Allspeeds Holdings Ltd.
This document must not be modified in any way.

Description

The cutter is primarily intended for use on steel wire rope, having a maximum tensile strength of 1880N/mm and will cut ropes up to 190mm diameter. It may be used on alternative materials, such as electrical power or communication cables, again up to a maximum of 190mm diameter. Where smaller diameters are to be cut, effort should be made to place the material centrally along the anvil to minimise any offset loading. Two sets of steel jaw pads (wear plates) are supplied, to permit reduction of the jaw width. One pair (20mm thick) for cutting materials up to 155mm diameter, and one pair (8mm thick) for materials in the range 155mm to 190mm diameter

IMPORTANT

If it is required to extend the recommended use of the cutter, for instance to cut solid steel bar, please refer to the manufacturer with full details of material size and tensile strength. Cutting unsuitable materials could result in damage to the tool.

1. SAFETY

Before operation, read and understand this operations manual.

Whilst the tool is intended for remote or local operation sub-sea, there is no reason why it should not be used above surface.

Ensure that the tool, hoses and pump are in good condition and properly connected.

Ensure that suitable pressure regulation equipment is used and that the unit is not subjected to pressures higher than those stated in section 3

In all cases, where an operator is present, the safety aspects must be reviewed before the cutting operation is commenced.

No attempt should be made to cut any material that is under tension.

Ensure that the operator is shielded from the cutting blade during the cutting operation.

When cutting near the very end of the wire rope fragments can be expelled from the tool, please ensure that the operator is shielded from these.

If in doubt please contact the manufacturer (Allspeeds Ltd) or an authorized distributor for assistance.

If at any time it is necessary to carry out proof tests on the tool, e.g. after service on the hydraulic cylinders, it must be returned to the supplier for testing where the following procedures apply.

The maximum proof test pressure should not exceed 125% of the maximum working pressure and this should only be done by Allspeeds using our specially adapted test rig.

The tool should be guarded during the proof test operation, and be carried out in a safe working environment.

The proof pressure should be applied gradually, until the maximum pressure is reached.

Important: Please note this tool is designed for intermittent subsea use. Please refer to the manufacturer (Allspeeds Ltd) or an authorized distributor should you wish to use this tool subsea for any period over 14 days.

CAUTION – Any modification made to this tool will invalidate the warranty and may lead to equipment failure or personal injury. If in doubt please contact the manufacturer (Allspeeds Ltd) or an authorised distributor for assistance.

INSPECT THE TOOL BEFORE USE

With the cutter isolated from the hydraulic supply, check the condition of the blade edge. If the blade is damaged or blunt replace with a fresh blade before cutting. This procedure is as described in section 8.

Ensure that care is taken when checking the blade as the edge may be sharp

Check the condition of the anvil. It is normal that the anvil will show an indent where the blade has pressed down into it and can withstand multiple cuts, but any excessively damaged anvil should be replaced. This procedure is as described in section 7

CAUTION – USE OF BLADES AND PARTS NOT APPROVED BY WEBTOOL MAY RESULT IN TOOL FAILURE AND CONSEQUENTIAL DAMAGE

2. CUTTING CAPACITY

The cutter is primarily intended for use on steel wire rope, having a maximum tensile strength of 1880N/mm and will cut ropes up to 190mm diameter. It may be used on alternative materials, such as electrical power or communication cables, again up to a maximum of 190mm diameter. Where smaller diameters are to be cut, use the thicker set of wear plates provided, effort should be made to place the material centrally along the anvil to minimise any offset loading.

3. INSTALLATION

Tapped Holes, M16, are provided in the tool body (see sketch) which can be used for any attachment necessary to mount the cutter. The cylinder is a pressure vessel and is not recommended as a mounting point, the cylinder should not be drilled, machined, mutilated or damaged in any way, any warranty could be invalidated by such actions.

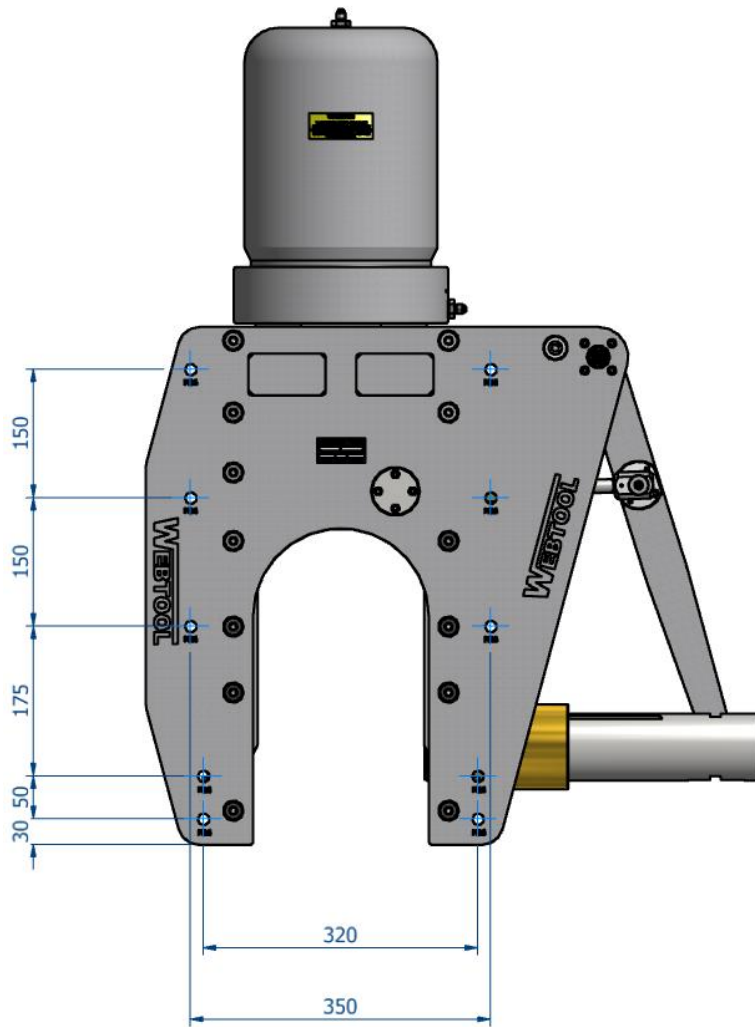

Two hydraulic supplies are required, ported as shown below. The maximum working pressures are shown in the table below and pressure limiting valves must be fitted into the supply to limit the pressures to these levels.

The weight of the tool is 295kg.

TABLE 1.

Function	Max. Working Pressure		Swept Volume		Port Tapping
	psi	bar	ml.	U.S. Gallon	
Main Ram Working Stroke	10,000	690	5200	(1.374)	¼" BSP
Main Ram Return Stroke	10,000*	210*	1390	(0.367)	¼" BSP
Auxiliary Cylinders Out Stroke (to retract anvil)	2,750	190	100	(0.026)	¼" NPT
Auxiliary Cylinders Instroke (to reset anvil)	2,750	190	60	(0.016)	¼" NPT

***N.B.** Actual pressure required to return Ram < 200 psi (14 bar). The pressure is regulated with a relief valve set to 250 bar

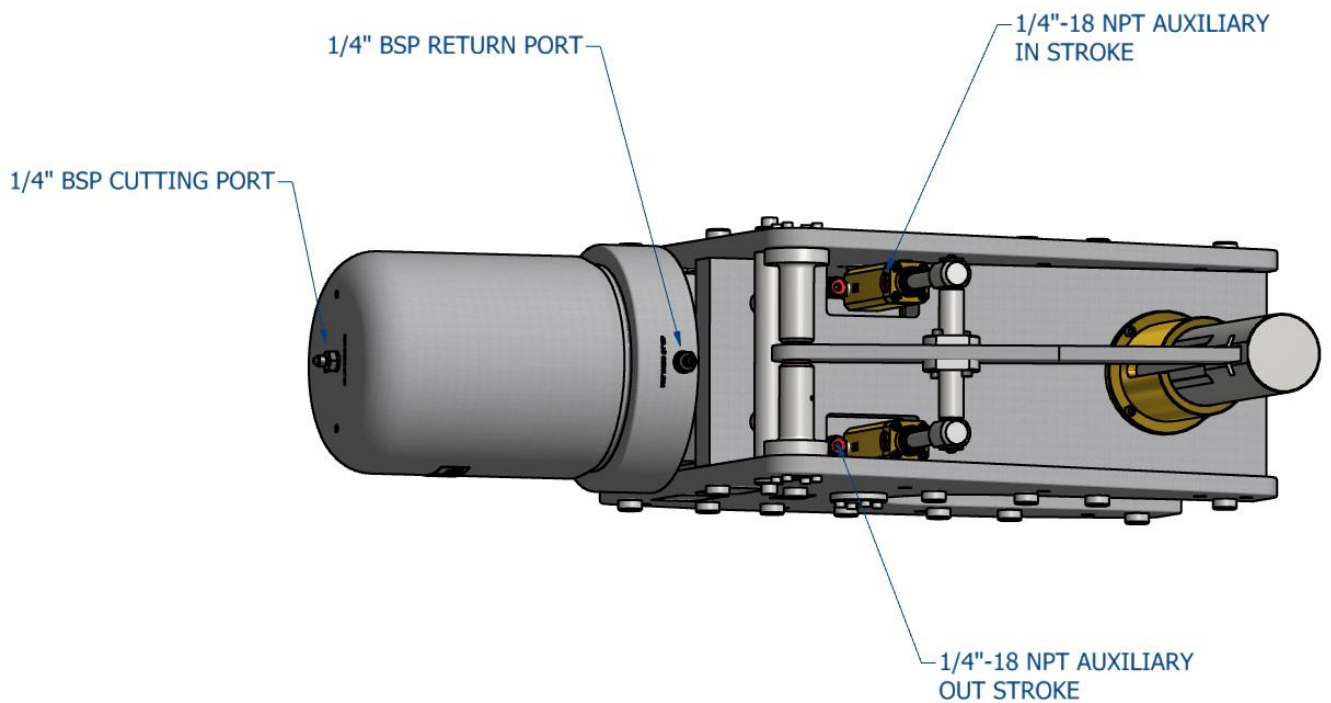

4. OPERATION

Before deployment, function test the tool and ensure that all operators are familiar with this procedure. ROV observation of the tool should be maintained at all time during operation. Prior to use, ensure no damage has occurred to the blade or anvil. Ensure the anvil is fully retracted.

DEPLOYMENT

Prior to use, the auxiliary cylinder outstroke should be operated to withdraw the anvil. This clears access for the cutter to be placed over the wire rope. Place the cutter over the wire rope. Ensure that the wire rope is as far into the cutter as possible so that the anvil does not foul as it is reset. Place the cutter over the wire rope.

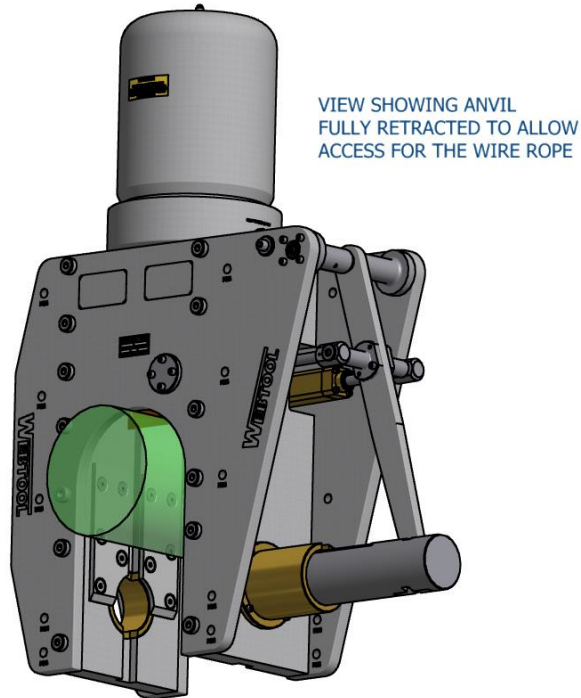

VIEW SHOWING ANVIL FULLY RETRACTED TO ALLOW ACCESS FOR THE WIRE ROPE

Operate the auxiliary cylinder in stroke to position the anvil fully home under the wire rope, the main ram should not be activated until the auxiliary cylinders are operated to the full extent of their stroke.

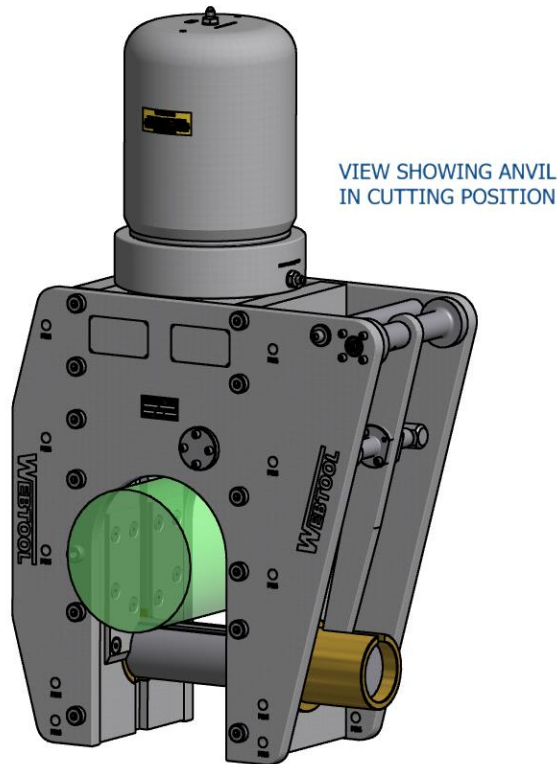

VIEW SHOWING ANVIL IN CUTTING POSITION

Operate the main ram down-stroke to sever the wire rope. Once the wire rope is severed, Pressurize the main ram retract port to withdraw the cutting blade. Then, and only then, retract the anvil. It is important not to operate the anvil cylinder whilst the main ram and blade are in the fully extended position.

If a further cut is required, the above procedure should be repeated.

N.B. Do not operate the auxiliary cylinders when the main ram is fully extended since this would damage the anvil.

Please note that this tool has a relief valve fitted which will blow off at approx. 750 bar, DO NOT leave the pressure on so that the relief valve is continually blowing off.

TROUBLESHOOTING

If the wire rope does not cut through completely on the first attempt, cycle the blade by retracting it slightly and then attempting the cut again.

If the wire rope does not completely cut after multiple cycles of the blade, check the Input pressure to the main input of the cylinder. This can be a maximum of 700 bar (10,000psi).

If the wire rope to be cut is still not severed after multiple cycles and at a pressure of 700 bar, Retract the blade and then the anvil and return the tool to the surface for inspection of the blade and anvil, replace if necessary.

IMPORTANT NOTE – ENSURE THAT THE BLADE IS FULLY RETRACTED AND THAT ALL PRESSURE TO THE CUTTER IS RELIEVED AS IT IS RAISED TO THE SURFACE. FAILURE TO DO THIS CAN LEAD TO A DANGEROUS BUILD UP OF PRESSURE IN THE CYLINDER.

5. AFTER USE

When the tool is retrieved, it should be hosed off with clean water, allowed to drain and sprayed externally with a de-watering fluid. Before storage, inspect the general condition of the tool. Particular attention should be paid to the anvil and blade. The anvil should be clean and free from any damage or bruising on the outside diameter that would prevent it from retracting properly. The blade edge should be smooth and free from any serrations. Note that a slight ripple to the blade edge is acceptable and will not cause problems. Any minor damage can be smoothed off with an oil stone if necessary.

6. SERVICE

It is unlikely that service would be required on the hydraulic components of the tool under normal circumstances, but a seal spares kit is available if required. The only parts that would need intermittent replacement would be the anvil, blade and wear plates, depending on the frequency of use and materials being cut. These parts can be ordered up on the following spares reference numbers, but in addition please quote the tool serial number.

Seal Kit	Part Number	995 133
Anvil	Part Number	SSC 6500
Blade	Part Number	705 064C
Wear Plate Kit 8mm thick	Part number	995 165
Wear Plate Kit 20mm thick	Part number	995 082

We advise that any servicing should be carried out by an authorised distributor only. If required, the tool can be returned to the manufacturer (Allspeeds Ltd.) for servicing and testing.

If servicing is to be undertaken by the user, please see note on proof testing under SAFETY (Chapter 1), and the following:-

All servicing operations should be carried out in a clean environment to prevent contamination of the oil and mating components.

Care should be taken with all mating areas ie. threads and sealing faces, as any damage or abrasive contamination could cause galling or seizing on re-assembly.

The cylinder is a pressure vessel and should not be drilled, machined, mutilated or damaged in any way for mounting purposes or to assist in its removal for servicing, any warranty could be invalidated by such actions.

The use of stilsons to remove the cylinder is not recommended as damage will occur.

7. REPLACEMENT OF THE ANVIL

Extend the auxiliary cylinders so that the lever arm 765309 exits the anvil guide bush 715365.

Loosen the 8 off M6 screws 035079 holding pivot pin housings 749045A & B.

Loosen the M6 retaining screw 035073.

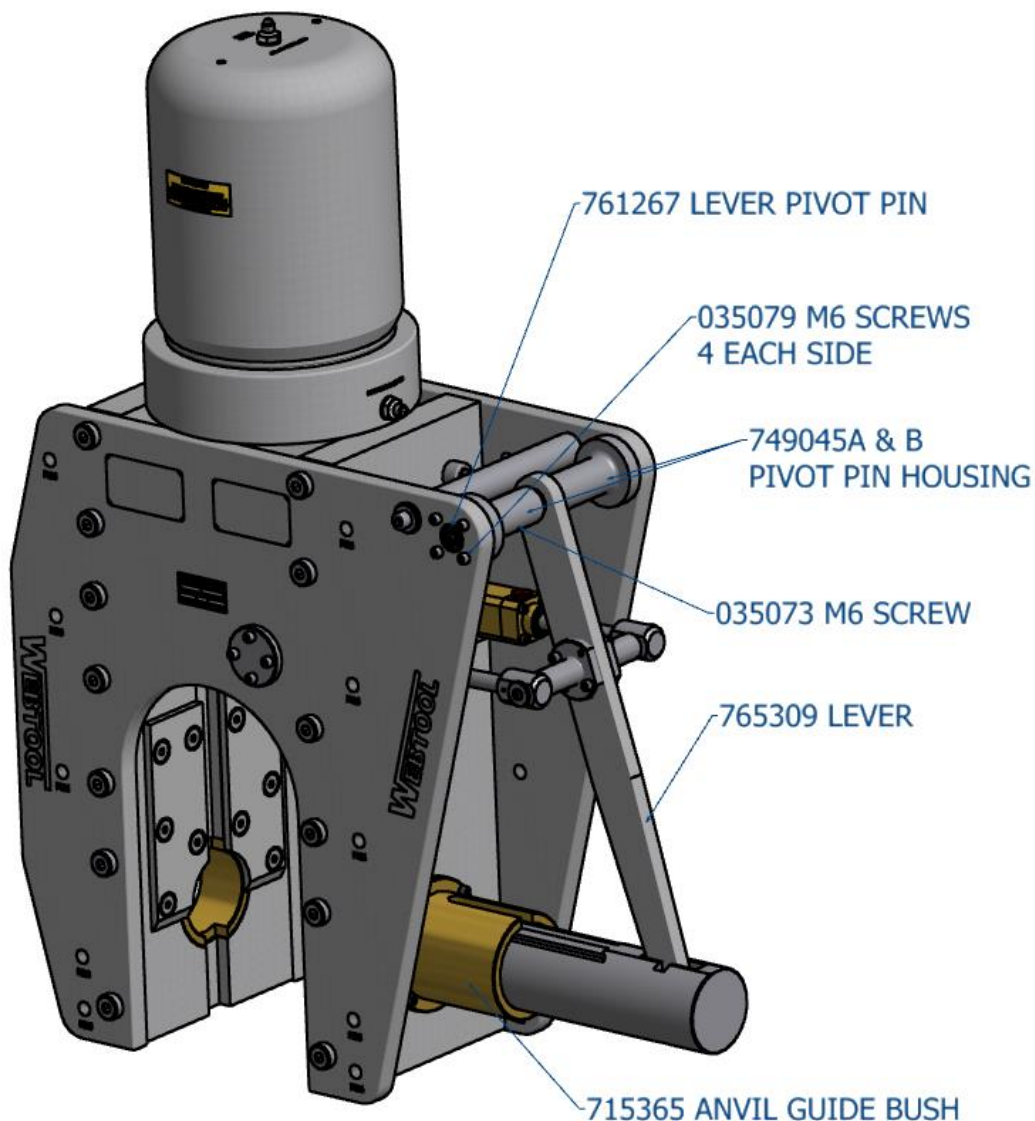

Withdraw the pivot pin 761267 far enough to release the lever arm. (There is an M6 tapped hole in the end of the pivot pin to assist in withdrawing this)

The lever arm can be moved upwards to separate it, with the anvil pin 761247, from the anvil SSC6500. The anvil may now be slid out from the anvil guide bush.

Re-assembly is the reverse of the above process.

8. REPLACEMENT OF THE CUTTING BLADE

First withdraw the anvil as described above.

Pump out the main ram until the blade spring pins 030636 can be seen in the opening of the cutter body.

The three pins are ¼" (6.35mm) diameter and they should be knocked out enough to release the blade.

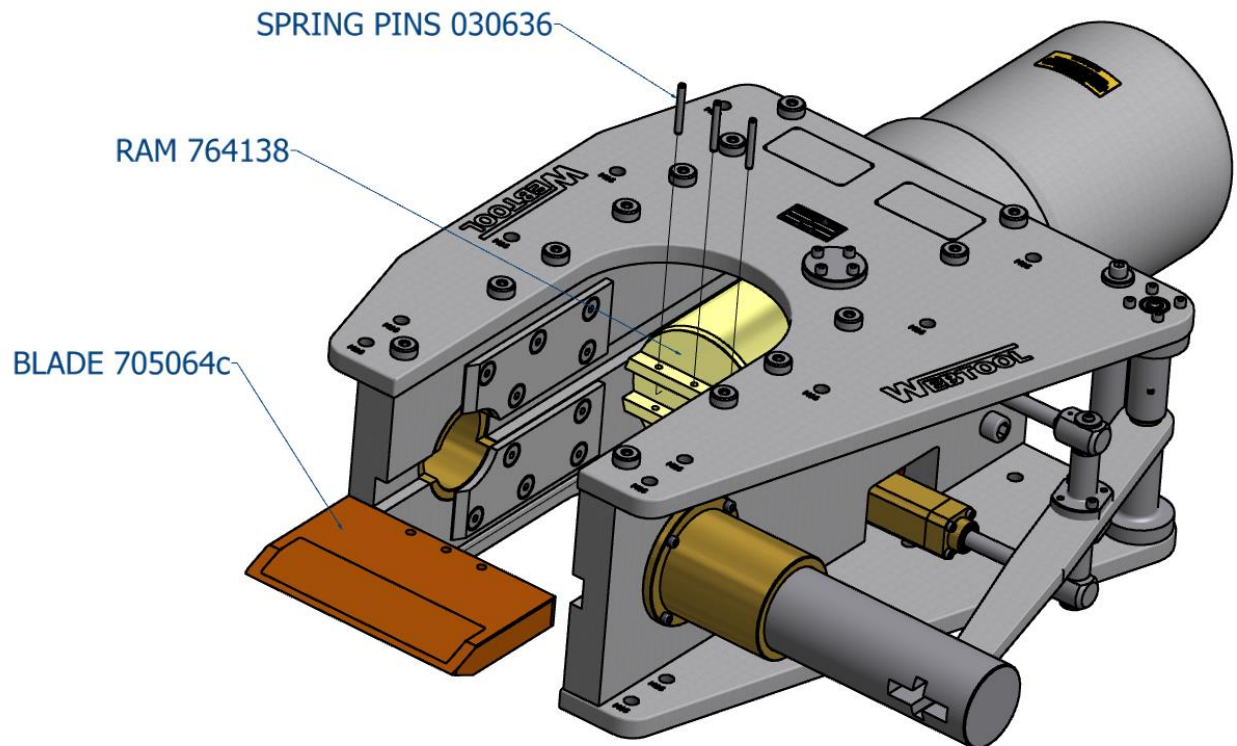

With the pins removed the blade can be taken from the cutter, gloves should be worn to prevent cuts from any sharp edges that may be present on the blade after use.

Re-assembly is the reverse of the above process.

9. REMOVAL OF THE MAIN CYLINDER

If it is necessary to renew the hydraulic seals, the cylinder must be removed from the tool. As an aid to this, 2 off tapped holes are provided in the cylinder end face. These are M8 x10 deep on 136mm centres.

A cylinder assembly tool is available if required part number SK4377A.

First, remove the anvil as described above in section 7, pump out the ram and remove the blade, again as described above in section 8.

To use the holes in the top of the cylinder first remove the coupling, then the blanking screws 035114 and fasten a piece of flat bar, typically 30x10mm section and 900mm long centrally to the top of the cylinder. This can be used to loosen or re-tighten the cylinder. Do not use Stilsons to remove the cylinder as damage will occur.

Unscrew the cylinder 728090 and remove from the assembly, it will come free but still attached will be the ram 764138.

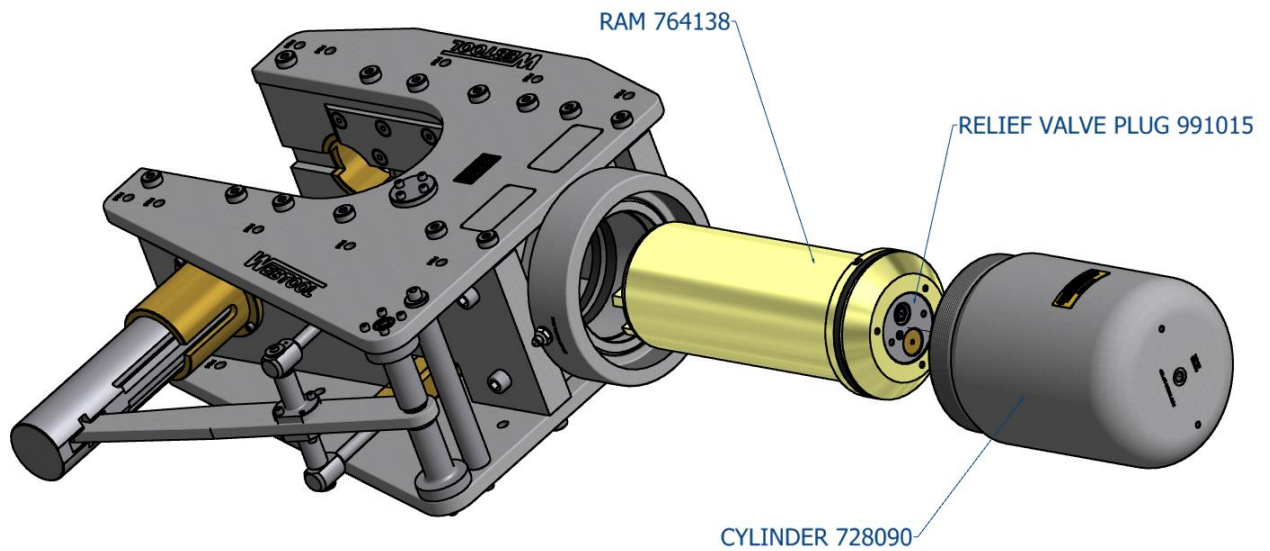

Put the assembled parts into a plastic dust bin or similar vessel, fit the coupling to the top of the cylinder, attach a hand pump to the coupling and pump out the ram, importantly, **by hand**. The ram will now be free of the cylinder and all seals will be accessible.

The ram has been fitted with a relief valve plug, this also contains seals, to remove the part the two M8 tapped holes can be used to unscrew the plug, the two relief valves have been careful set to blow off at a set pressure, these can be removed with a 17mm socket and 5mm allen key, care should be taken not to disturb the settings.

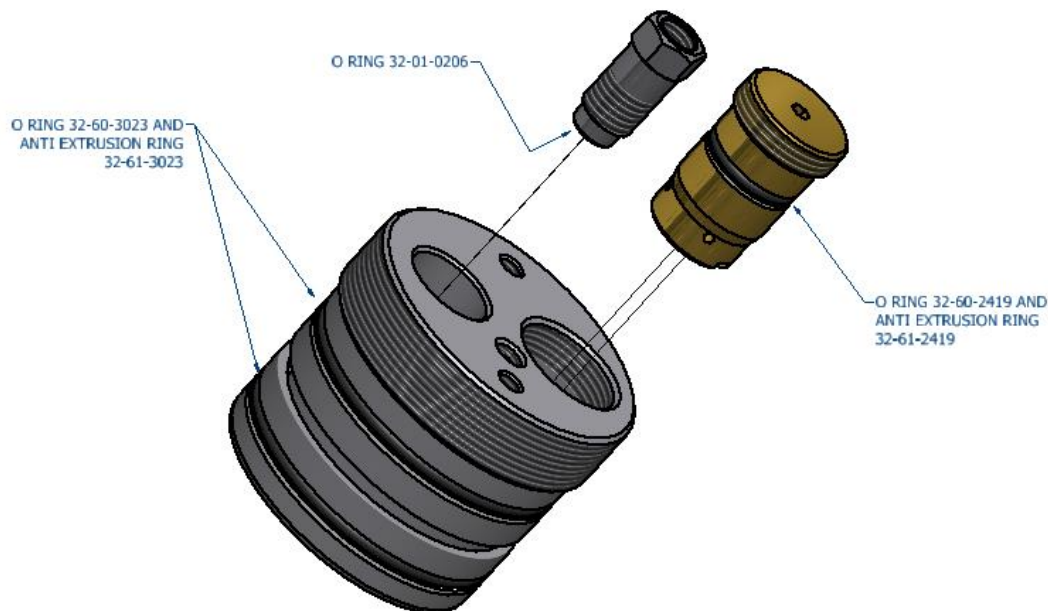

When re assembling the relief valve plug with the ram, first fill the ram with oil to the bottom of the counterbore, smear silver goop on to the threads of the plug, screw in the plug, remove the set screw and ball in the top of the plug and top up the inside of the ram with oil until it fills the screw hole, fit the ball and screw and lock tight.

Check that the plug and the relief valves are tight and below the top face of the ram.

Fit the ram into the assembly, locate the blade and fit the spring pins, put grease on the threads and screw in the cylinder using the two tapped holes and the flat bar, remove the bar, replace the screws and fit the coupling and bonded seal.

Re fit the anvil lever etc. The tool is now ready for use.

RCV 190 – Full Part List excluding seals		980230
Part No.	Description	Qty.
728090	Cylinder	1
764138	Ram	1
765312A	Wear plate 8mm thick	2
765312B	Wear plate 8mm thick	2
749045A	Pivot pin housing, left	1
749045B	Pivot pin housing, right	1
SSC6500	Anvil	1
761247	Pin, sliding, anvil	1
715365	Anvil guide bush	1
715355	Anvil bush	1
761247	Sliding anvil pin	1
705064c	Blade	1
761267	Lever pivot pin	1
761268	Cylinder rod pin, auxiliary cylinder	2
765309	Lever	1
080971	Special washer M6	4
079044	Mounting stud, auxiliary cylinder	2
715345	Lever pivot pin bush	2
765310A	Wear plate 20mm thick	2
765310B	Wear plate 20mm thick	2
709087	Piston block	2
728078	Cylinder, auxiliary	2
SSC6476	Auxiliary end cap	2
764116	Auxiliary piston	2
766093	Relief valve plug	1
026701	Pellet	2
043206	Socket set screw M4 x 6	2
035067	Socket cap screw M5 x 30	8
701195	Swagelok connector	2
035111	Socket cap screw M6 x 35	12
035079	Socket cap screw M6 x 25	8
035066	Socket cap screw M6 x 20	8
035076	Socket cap screw M6 x 16	5
035073	Socket cap screw M6 x 10	1
035114	Socket set screw M8 x 10	2
035136	Socket c'sunk headed screw M10 x 20	20
030636	Spring pin ¼" x 2"	3
752342	Nameplate	1
766047	Blanking plug	4
791157	Coupling ¼" BSP to No.4 JIC	2
035080	Socket set screw	1
31-47-0310	Blanking ball	1
752573	Pressure warning label	1
31-99-2834	Eye bolt	6
982144	Body sub-assembly	1
1155006	Relief valve 700 bar	1
1155007	Relief valve 250 bar	1
035119	Socket cap screws for customer mounting M16 x 50 stainless	10

Seal Kit – Part List		995133
Part No.	Description	Qty.
025311	Seal, 'O' ring, end cap	2
025569	Scraper, rod	2
025801	Seal, piston	2
025802	Seal, rod	2
025917	Main piston seal	1
025918	Main rod seal	1
025670	Seal O ring	1
025919	Main wiper seal	1
32-60-3023	O ring relief valve plug	2
32-61-3023	A/E for 32-60-3023	2
32-60-2419	O ring for relief valve	1
32-61-2419	A/E ring for 32-60-2419	1
32-01-0206	O ring for relief valve	1
32-07-0035	Bonded seals	2

Replacement Auxiliary cylinders can be ordered under the part number 982145, a full list of auxiliary parts are shown below

Auxiliary Cylinder – Part List		982145
Part No.	Description	Qty.
709087	Piston block	1
728078	Cylinder	1
SSC6476	End cap	1
764116	Piston	1
026701	Pellet	1
043206	Socket set screw M4 x 6	1
035067	Socket cap screw M5 x 30	4
701195	Swagelok connector	1
025311	Seal, 'O' ring, end cap	2
025569	Scraper, rod	2
025801	Seal, piston	2
025802	Seal, rod	2

Replacement Relief valve plug assemblies can be ordered under the part number 991015, a full list of these parts are shown below

Relief valve plug kit – Part List		991015
Part No.	Description	Qty.
766093	Relief valve plug	1
32-60-3023	O ring relief valve plug	2
32-61-3023	A/E for 32-60-3023	2
32-60-2419	O ring for relief valve	1
32-61-2419	A/E ring for 32-60-2419	1
32-01-0206	O ring for relief valve	1
035080	Socket set ecrew	1
31-47-0310	Blanking ball	1
1155006	Relief valve 700 bar	1
1155007	Relief valve 250 bar	1

This RCV190 wire rope cutter is compatible with the following optional extras, not supplied as standard.

Cylinder Assembly Tool - SK4377A

This tool can be used on RCV75, RCV75HD, RCV115, RCV135, RCV155, RCV190, HCV100, HCV120, HCV250 and HCV270 cutting tools

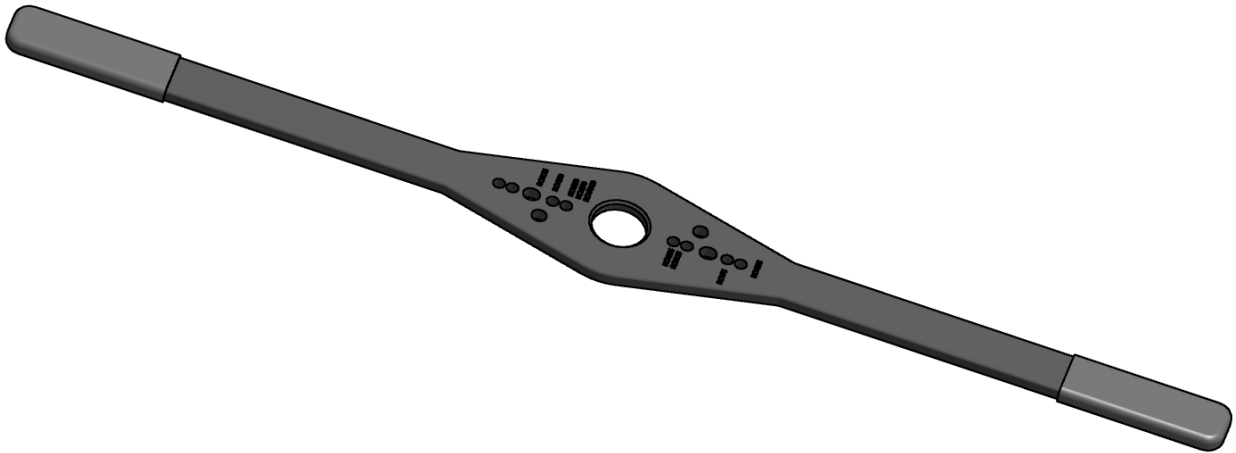

Webtool Hydraulic Intensifier – HP690A (available in a range on intensification ratios)



For further information contact the manufacturer (Allspeeds Ltd) or an authorised distributor.

WEBTOOLTM

CUTTING EDGE TECHNOLOGY

Webtool specialises in engineering powerful hydraulic tools for cutting and gripping rope, cable and umbilicals.

Models designed for use in subsea environments by ROV's, and surface applications in hostile environments.

- Wire rope cutters (WCS and WCOS) – capable of cutting steel wire rope up to 75mm diameter
- Wire Rope Cutters (RCV) – capable of cutting steel wire rope up to 190mm diameter
- Cable Cutters (HCV) – capable of cutting cable, umbilical and armoured flexible pipe lines up to 330mm diameter
- Softline Cutters (SL) – capable of cutting fibre ropes in various sizes
 - Wire Rope / Cable Grippers
 - Wire Rope Clamps
 - Automatic Shackles

Application specific solutions

Our in house design and manufacturing capability means we can quickly and efficiently develop a solution to suit your particular application. Contact our engineering department to discuss how we can help.

Allspeeds Ltd, Royal Works, Atlas Street, Clayton-Le-Moors,
Accrington, Lancashire, BB5 5LW, England

T: +44 (0)1254 615100
E: info@allspeeds.co.uk

F: +44 (0)1254 615199
W: www.allspeeds.co.uk